

GULLBERG *GJ* JANSSON

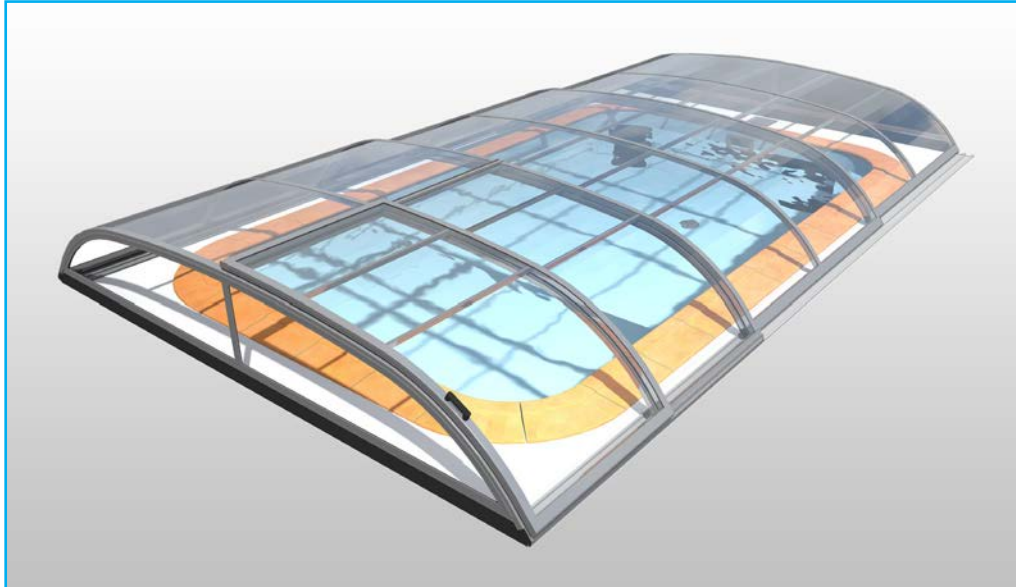

P O O L E N C L O S U R E S

NOVA COMFORT
& STELLA COMFORT

Assembly manual

Model				Outside dimensions			Weight
Name	Type	Glazing	Width	Height	Depth	kg	
Nova Comfort 3x6	A3	TH*	4750	1350	410	245	
Nova Comfort 3x7,5	A3/4		4750	1350	410	320	
Nova Comfort 3,5x7	A4S		5250	1350	410	310	
Nova Comfort 3,5x8,5	A4L		5250	1350	410	340	
Nova Comfort 4x8	A4		5950	1350	410	400	
Nova Comfort 4x10	A4/5		5950	1350	410	475	
Nova Comfort 5x10	A5		6550	1350	500	590	
Nova Comfort 3x6	A3	CL**	4750	1350	410	310	
Nova Comfort 3x7,5	A3/4		4750	1350	410	400	
Nova Comfort 3,5x7	A4S		5250	1350	410	410	
Nova Comfort 3,5x8,5	A4L		5250	1350	410	430	
Nova Comfort 4x8	A4		5950	1350	410	450	
Nova Comfort 4x10	A4/5		5950	1350	410	550	
Nova Comfort 5x10	A5		6550	1350	500	760	

Model				Outside dimensions			Weight
Name	Type	Glazing	Width	Height	Depth	kg	
Stella Comfort 3x6	M3	TH*	5250	1350	410	310	
Stella Comfort 4x8	M4		6700	1840	410	510	
Stella Comfort 4x10	M4/5		6700	1840	410	630	
Stella Comfort 5x10	M5		6500	2000	540	750	
Stella Comfort 3x6	M3	CL**	5250	1350	410	350	
Stella Comfort 4x8	M4		6700	1840	410	540	
Stella Comfort 4x10	M4/5		6700	1840	410	660	
Stella Comfort 5x10	M5		6500	2000	540	860	

*TH: PC Thermo = double walled polycarbonate sheet

**CL: PC Clear = solid, transparent polycarbonate sheet

BOX DISASSEMBLY



1

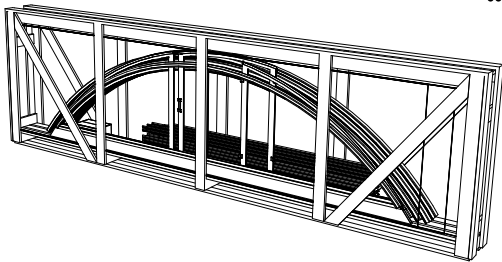

2

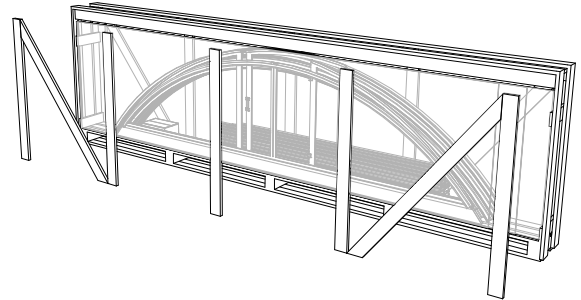

3

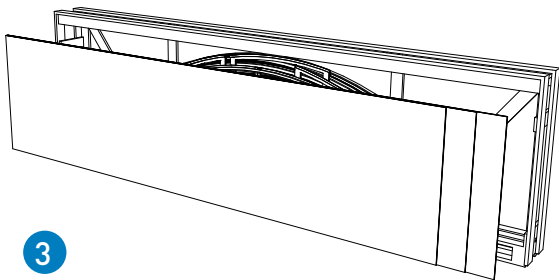

4

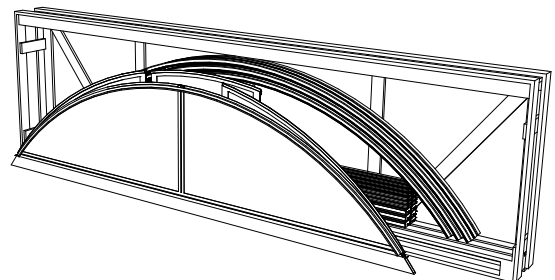

5

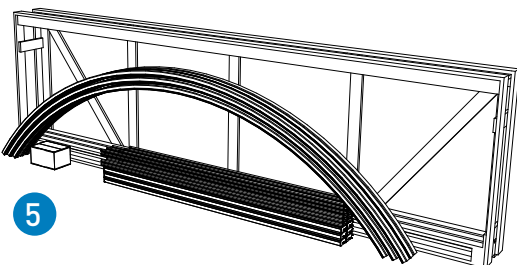



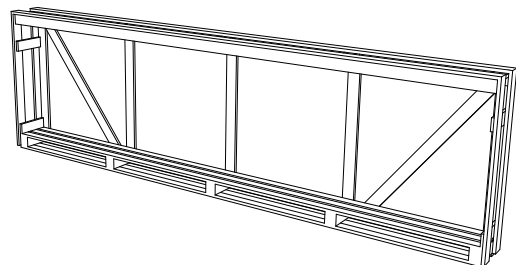









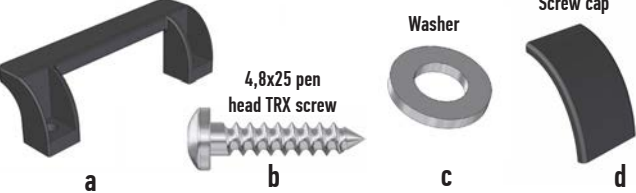

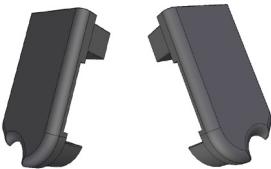
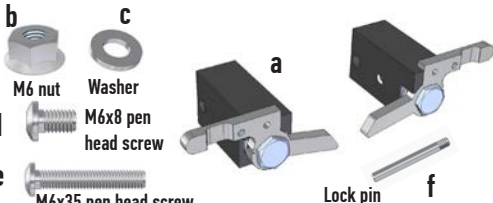



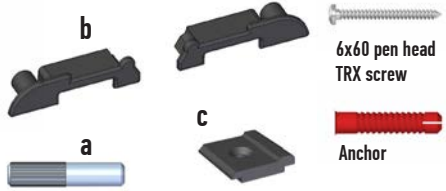
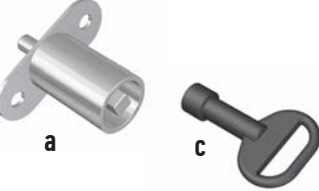

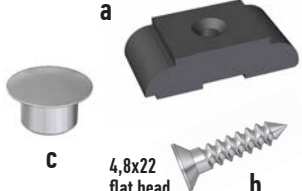
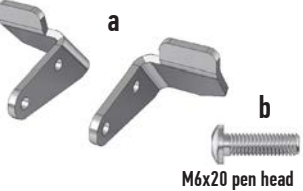
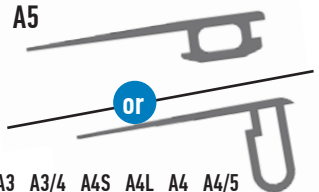
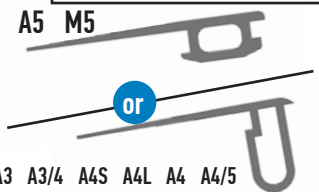

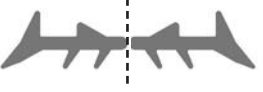

6



Part list		
No.	Name	Type
1	4,8x50 pen head TRX screw	71300
2a	Wedge + 4,2x10 pen head TRX screw	71349
2b	TRX screw	71385
3	Pop rivet 12 mm	71302
4a	Square lock	71372
4b	flat nut	71372
4c	plug	71373
5	6x60 pen head TRX screw	71364
6	Anchor	71365
7a	Interior handle	71320
7b	4,8x25 pen head TRX screw	71327
7c	Washer	71363
7d	Screw cap	71321
8a	Handle	71318
8b	Washer	71363
8c	4,8x50 pen head TRX screw	71300
8d	Screw cap	71319
9	Receiver profile cap L/R	71340/41
10a	Hidden arrest L/R	71376/77
10b	M6 nut	71382
10c	Washer	71363
10d	M6x8 pen head screw	71379
10e	M6x35 pen head screw	71378
10f	Lock pin	71370
11	Receiver profile cap (on rubber side) L/R	71338/39
12a	Rocker Lever	71375
12b	M6x35 pen head screw	71378
12c	M6 nut	71382
12d	Sleeve	71374
13	Latch Sleeve	71312
14a	Rail join comfort	71371
14b	Rail buffer comfort L/R	71347/48
14 c	Buffer comfort	71381
14d	6x60 pen head TRX screw	71364
14e	Anchor 6x60	71365
15	Sliding door lock	71331
15b	Sliding door key	71310
16	Front wall fixing nut	71325
16b	Front wall fixing nut lock	71324
17	Sliding door buffer	71317
17b	Screw	71326
17c	Plug anodized	71315
18	Buffer plate L/R	71358/71357
18b	Screw	71380
19	Sliding door frame rubber seal L/R	71322/62
20	Rubber seal between segments L/R	71322/34
21	Sliding door bottom rubber	71329
22	Outside rubber (double)*	71323

PART LIST

<p>1 4,8x50 pen head TRX screw</p> 	<p>2 Wedge + 4,2x10 pen head TRX screw</p> 	<p>3 Pop rivet 12 mm</p> 	<p>4 Square lock + flat nut + plug</p> 
<p>5 6x60 pen head TRX screw</p> 	<p>6 Anchor</p> 	<p>7 Interior handle</p> 	
<p>8 Handle</p> 	<p>9 Receiver profile cap L-R</p> 	<p>10 Hidden arrest L-R</p> 	
<p>11 Receiver profile cap (on rubber side) L-R</p> 	<p>12 Rocker lever</p> 	<p>13 Latch sleeve</p> 	<p>14 Rail joiner + rail end cap L-R + buffer</p> 
<p>15 Sliding door lock + key</p> 	<p>16 Front wall fixing nut</p> 	<p>17 Sliding door buffer + plastic plug + screw</p> 	<p>18 Buffer plate L-R + screw</p> 
<p>19 Sliding door frame rubber seal</p> 	<p>20 Rubber seal between segments</p> 	<p>21 Sliding door bottom rubber</p> 	<p>22 Outside rubber (double)*</p>  <p>*With PC Clear plates</p>

<p>T1</p> 	<p>T2</p>  <p>4.1 mm</p>	<p>T3</p>  <p>3.5 mm</p>	<p>T4</p>  <p>7 mm</p>	<p>T5</p>  <p>TRX 25</p>	<p>T6</p>  <p>TRX 20</p>	<p>T7</p> 	<p>T8</p> 	<p>T9</p> 
--	---	---	---	---	---	---	---	---

1 BOX DISASSEMBLY

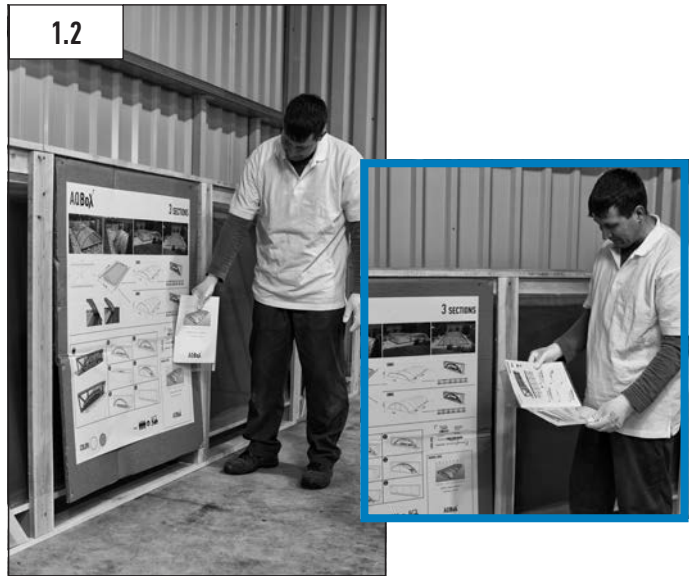

1 BOX DISASSEMBLY

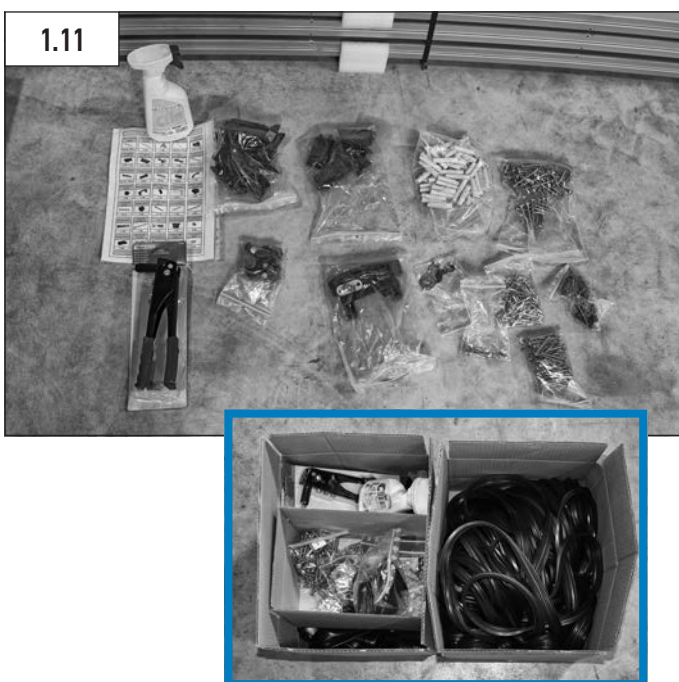
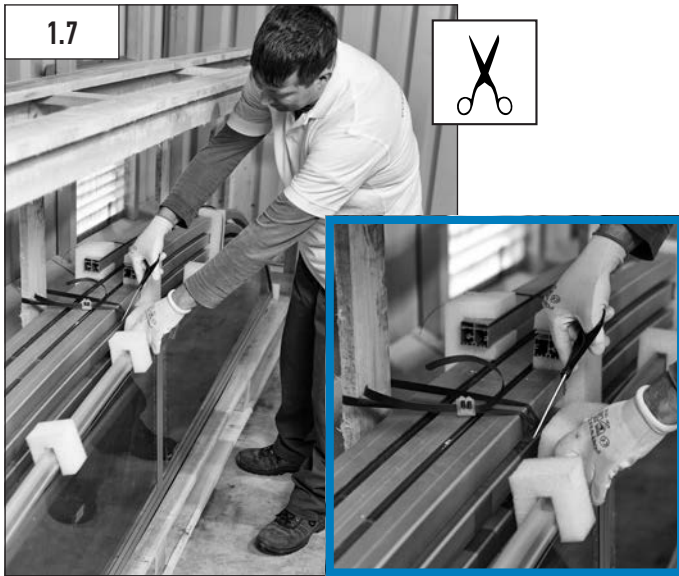

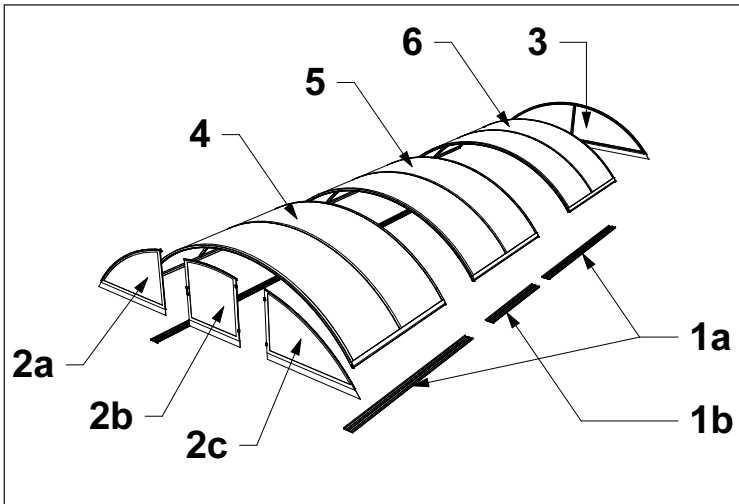

LIST OF ITEMS FOR M3 ENCLOSURES

Nr.	Item name	Item number	Pcs	Chapter
1a	Rail	S3/3	4	2
1b	Rail	S4/3	2	2
2a	Front wall		1	8
2b	Front wall		1	8
2c	Front wall		1	8
3	End wall		1	8
4	1. segment		1	3
5	2. segment		1	4
6	3. segment		1	4

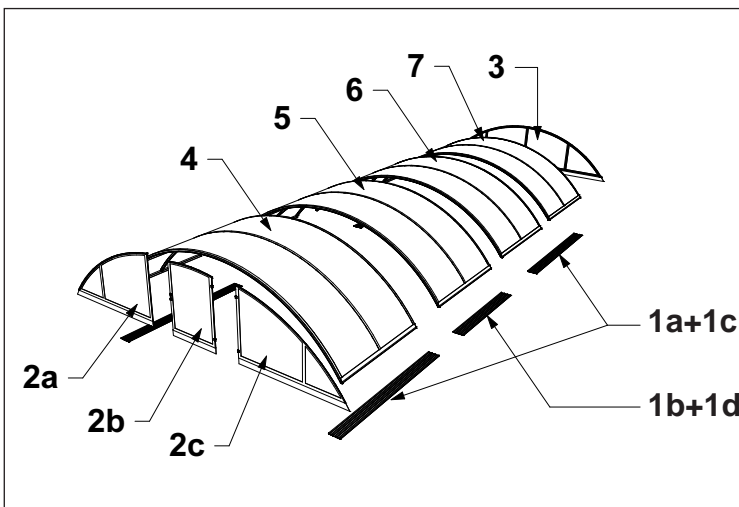

LIST OF ITEMS FOR M4 ENCLOSURES

Nr.	Item name	Item nr.	Pcs	Chapter
1a	Rail	S1/2	4	2
1b	Rail	S3/2	4	2
1c	Rail	S1/2s	2	2
1d	Rail	S3/2s	2	2
2a	Front wall		1	8
2b	Front wall		1	8
2c	Front wall		1	8
3	End wall		1	8
4	1. segment		1	3
5	2. segment		1	4
6	3. segment		1	4
7	4. segment		1	4

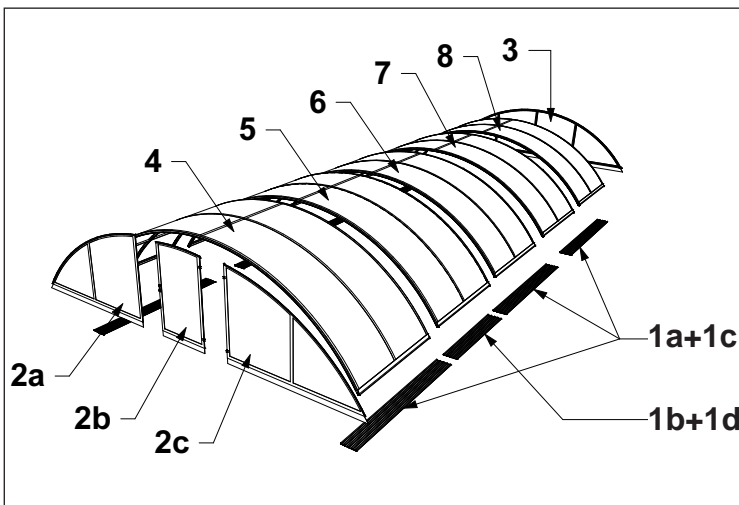

LIST OF ITEMS FOR M4/5, M5 ENCLOSURES

Nr.	Item name	Item number	Pcs	Chapter
1a	Rail	S1/3	6	2
1b	Rail	S7/3	6	2
1c	Rail	S1/2s	4	2
1d	Rail	S7/2s	4	2
2a	Front wall		1	8
2b	Front wall		1	8
2c	Front wall		1	8
3	End wall		1	8
4	1. segment		1	3
5	2. segment		1	4
6	3. segment		1	4
7	4. segment		1	4
8	5. segment		1	4

PART LIST BY ENCLOSURE TYPES

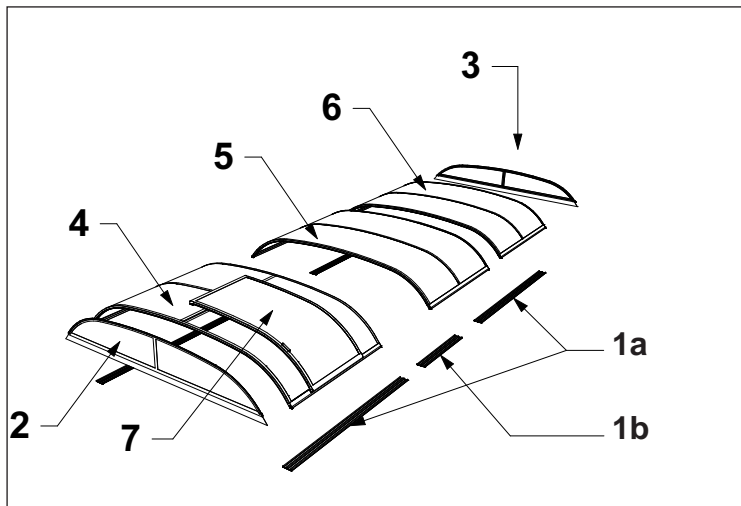

LIST OF ITEMS FOR A3 ENCLOSURES				
Nr.	Item name	Item number	Pcs	Chapter
1a	Rail	S3/3	4	2
1b	Rail	S4/3	2	2
2	Front wall		1	8
3	End wall		1	8
4	1. segment		1	3
5	2. segment		1	4
6	3. segment		1	4
7	Side mounted sliding door		1	6

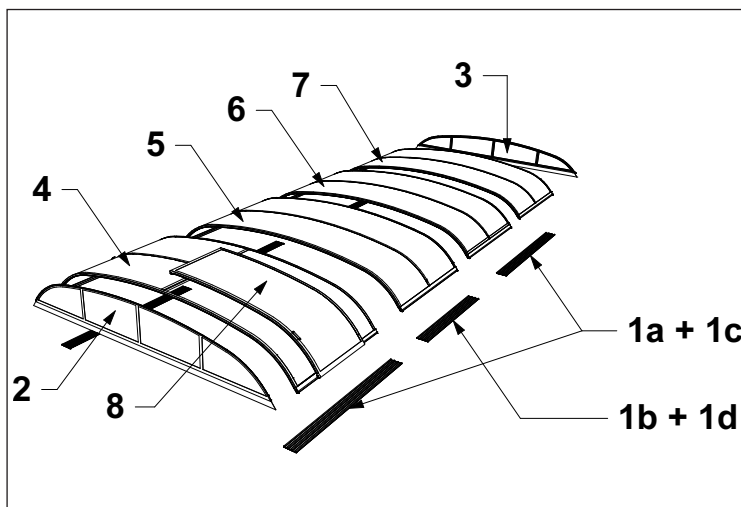

LIST OF ITEMS FOR A3/4, A4S, A4L, A4 ENCLOSURES							
Nr.	Item name	Item number A3/4	Item number A4S	Item number A4L	Item number A4	Pcs	Chp.
1a	Rail	S1/2	S1/2	S1/2	S1/2	4	2
1b	Rail	S5/2	S6/2	S2/2	S3/2	4	2
1c	Rail	S1/2s	S1/2s	S1/2s	S1/2s	2	2
1d	Rail	S5/2s	S6/2s	S2/2s	S3/2s	2	2
2	Front wall					1	8
3	End wall					1	8
4	1. segment					1	3
5	2. segment					1	4
6	3. segment					1	4
7	4. segment					1	4
8	Sliding door					1	6

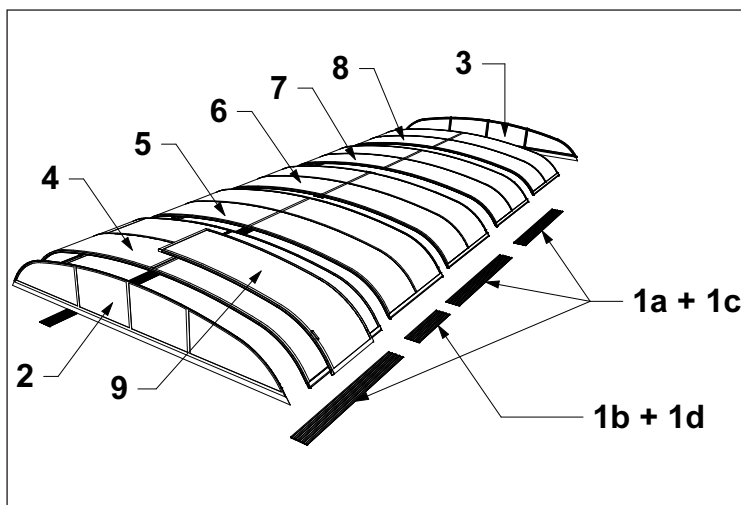

LIST OF ITEMS FOR A4/5, A5 ENCLOSURES				
Nr.	Item name	Item number	Pcs	Chapter
1a	Rail	S1/3	6	2
1b	Rail	S7/3	6	2
1c	Rail	S1/2s	4	2
1d	Rail	S7/2s	4	2
2	Front wall		1	8
3	End wall		1	8
4	1. segment		1	3
5	2. segment		1	4
6	3. segment		1	4
7	4. segment		1	4
8	5. segment		1	4
9	Side mounted sliding door		1	6

Rail placement

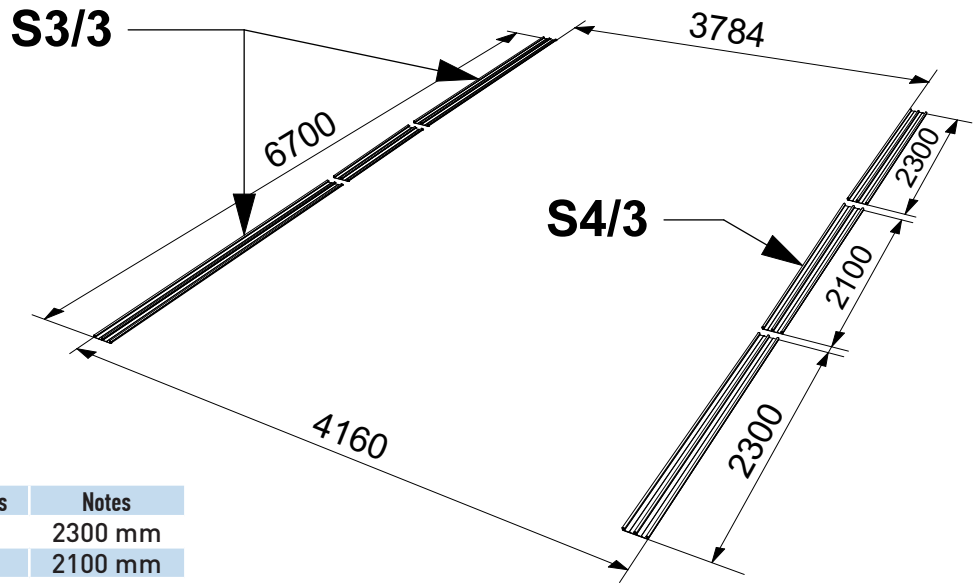

Item Nr.	Item name	Pcs	Notes
S3/3	Rail	4	2300 mm
S4/3	Rail	2	2100 mm
5	Pen head screw	36	6x60
6	Anchor	36	
14a	Rail joiner	12	

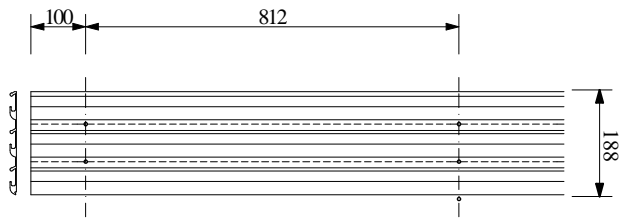

Suggested spots for holes on the rail
(depending on the ground surface)

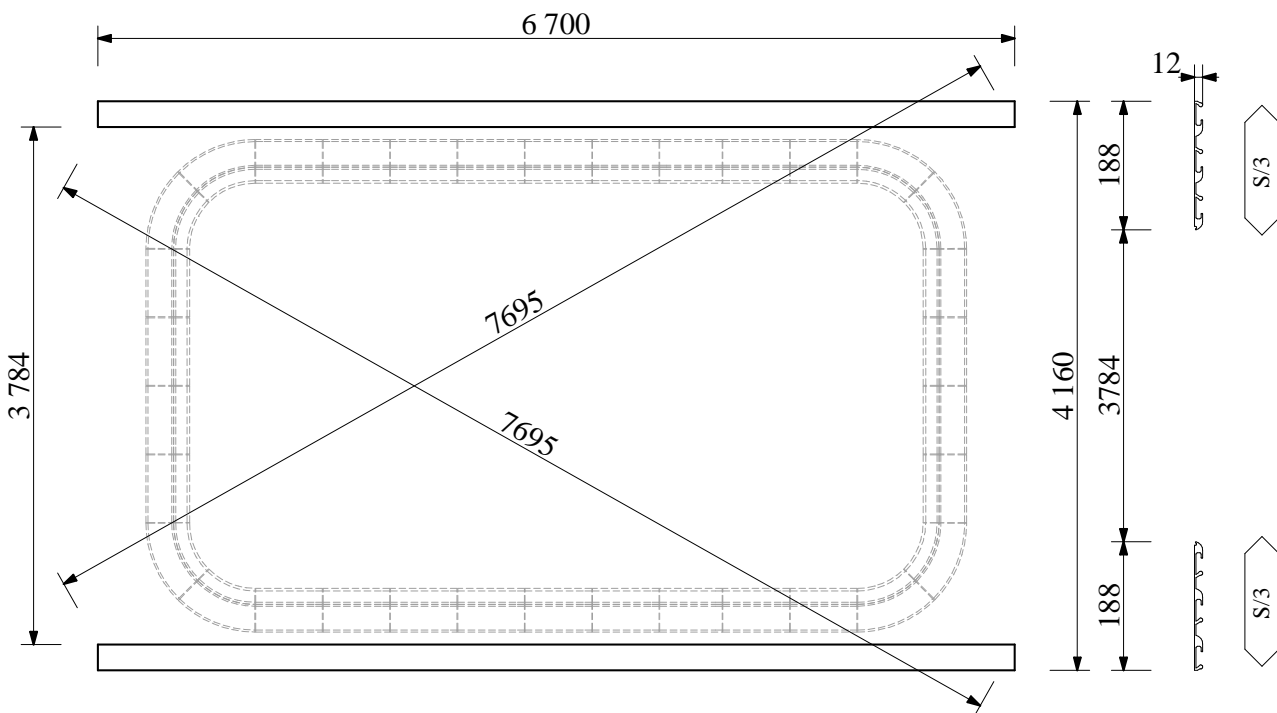
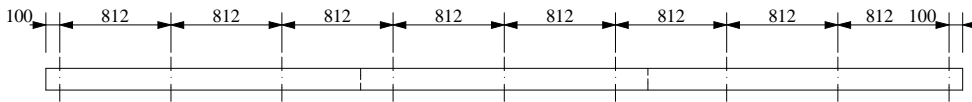

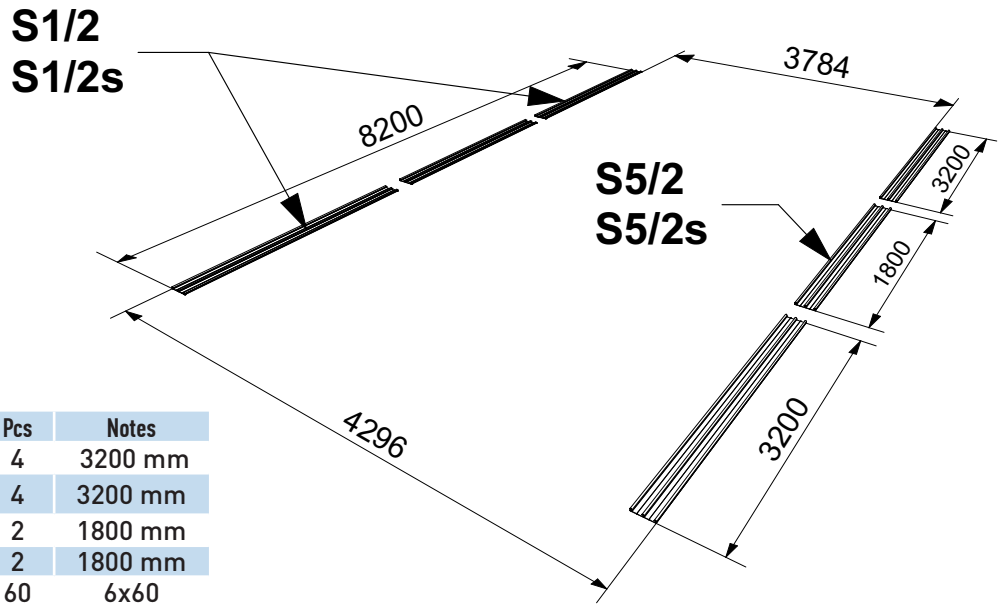

Item Nr.	Item name	Pcs	Notes
S1/2	Rail	4	3200 mm
S1/2s	Rail	4	3200 mm
S5/2	Rail	2	1800 mm
S5/2s	Rail	2	1800 mm
5	Pen head Screw	60	6x60
6	Anchor	60	
14a	Rail joiner	16	

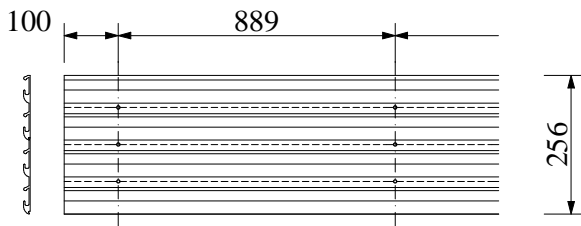

Suggested spots for holes on the rail (depending on the ground surface)

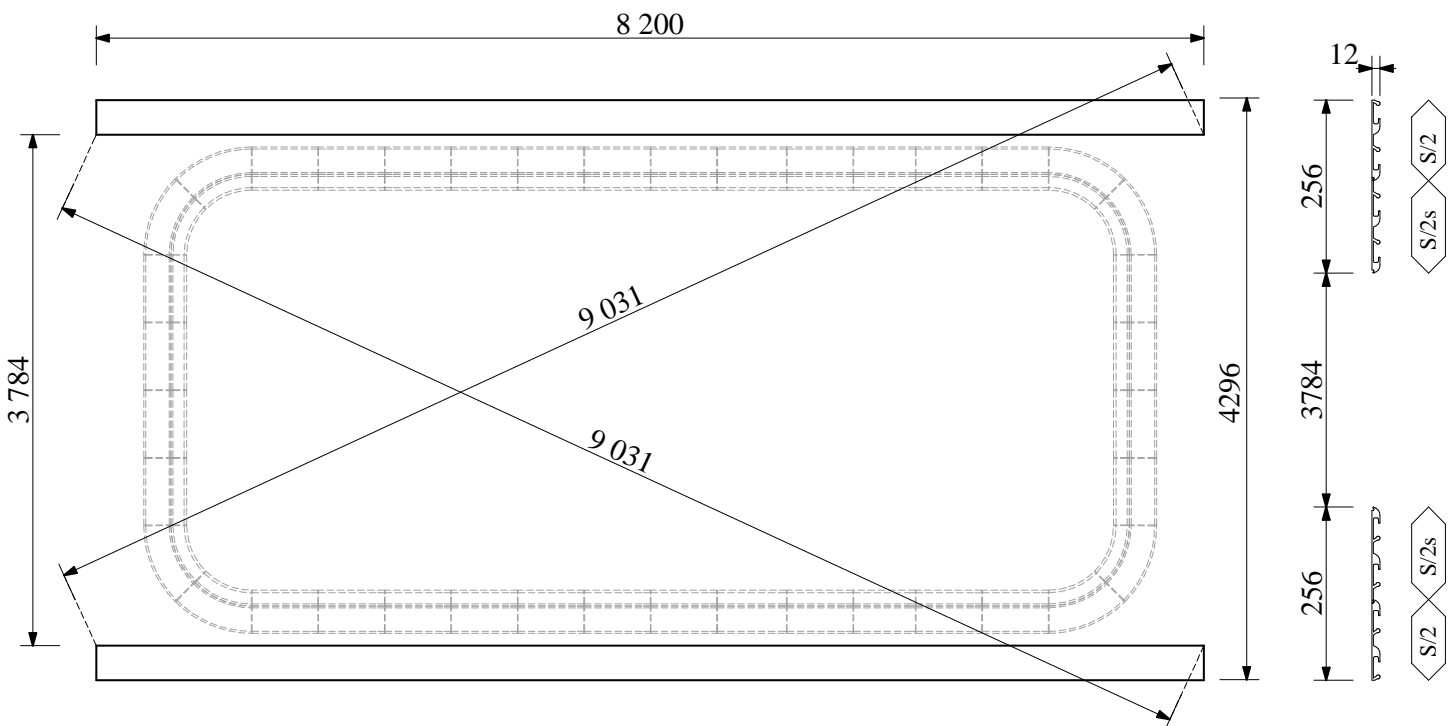
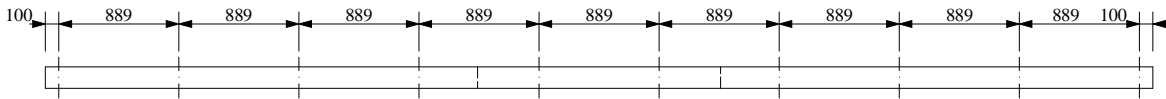

rail placement

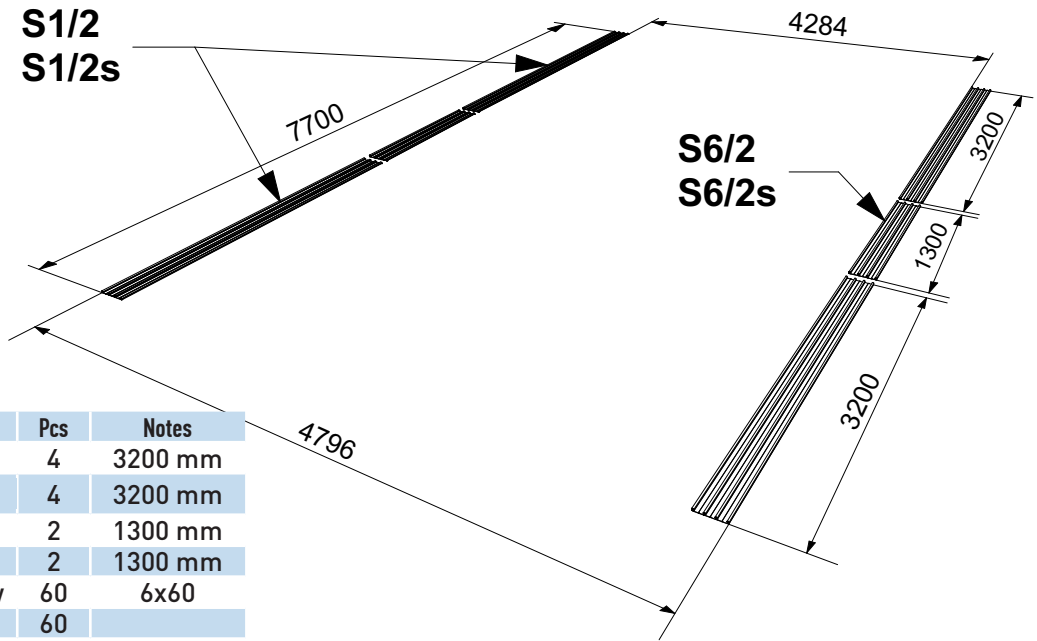

Item Nr.	Item name	Pcs	Notes
S1/2	Rail	4	3200 mm
S1/2s	Rail	4	3200 mm
S6/2	Rail	2	1300 mm
S6/2s	Rail	2	1300 mm
5	Pen head Screw	60	6x60
6	Anchor	60	
14a	Rail joiner	16	

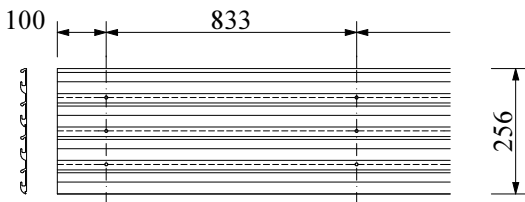

Suggested spots for holes on the rail
(depending on the ground surface)

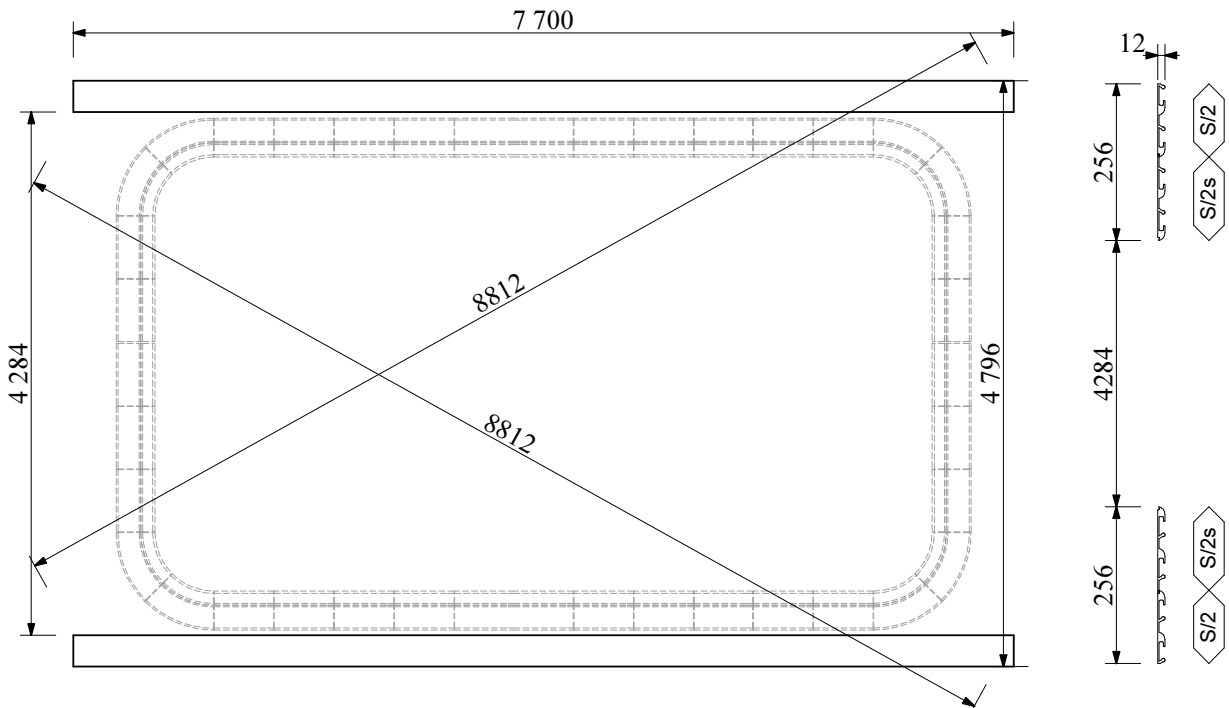
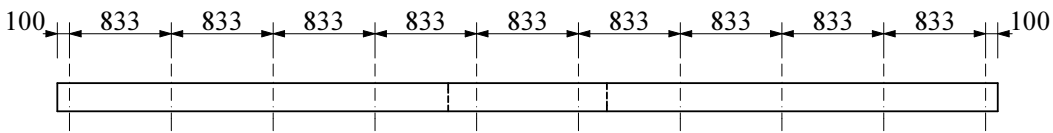

rail placement

Item Nr.	Item name	Pcs	Notes
S1/2	Rail	4	3200 mm
S1/2s	Rail	4	3200 mm
S2/2	Rail	2	2800 mm
S2/2s	Rail	2	2800 mm
5	Pen head Screw	72	6x60
6	Anchor	72	
14a	Rail joiner	16	

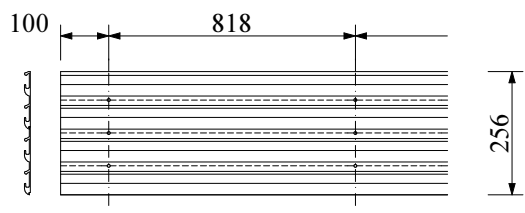

Suggested spots for holes on the rail (depending on the ground surface)

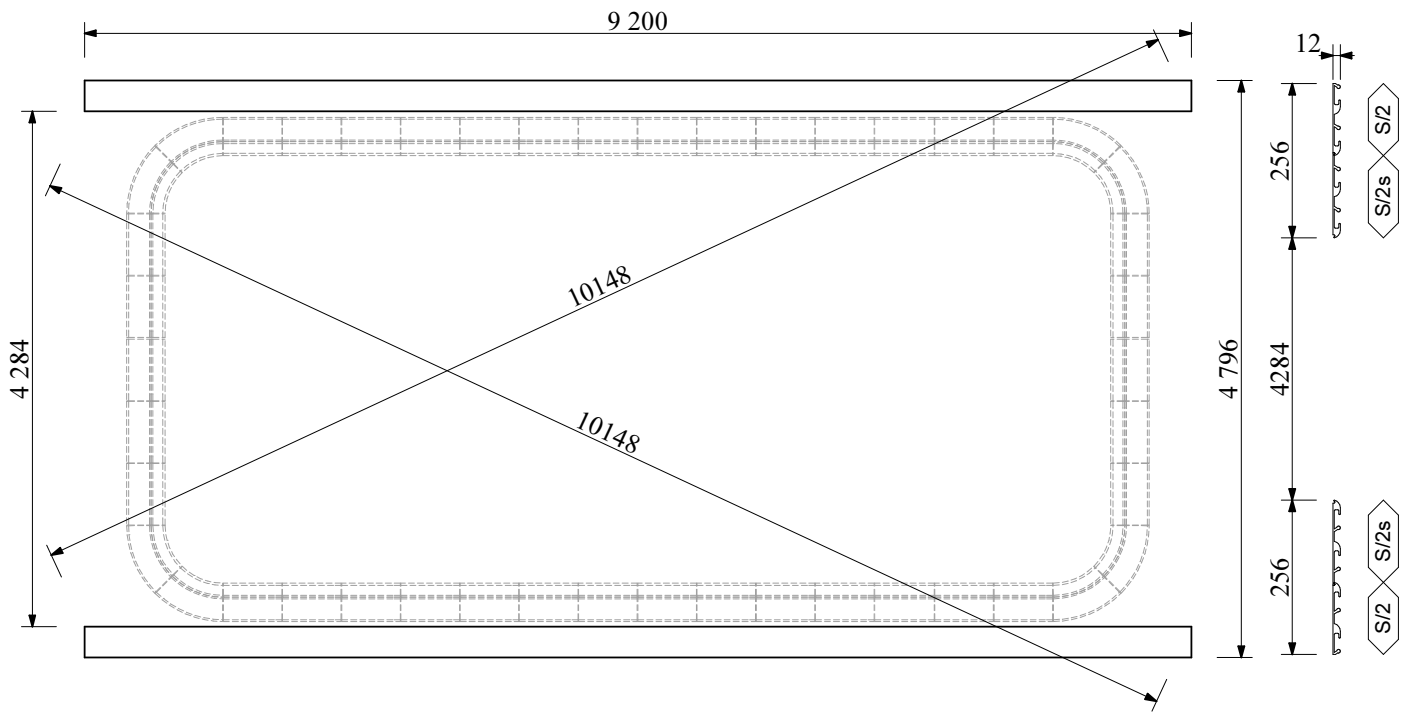
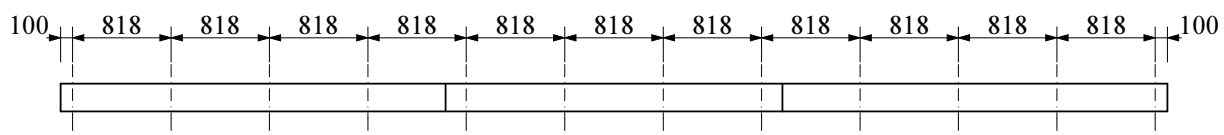

Rail placement

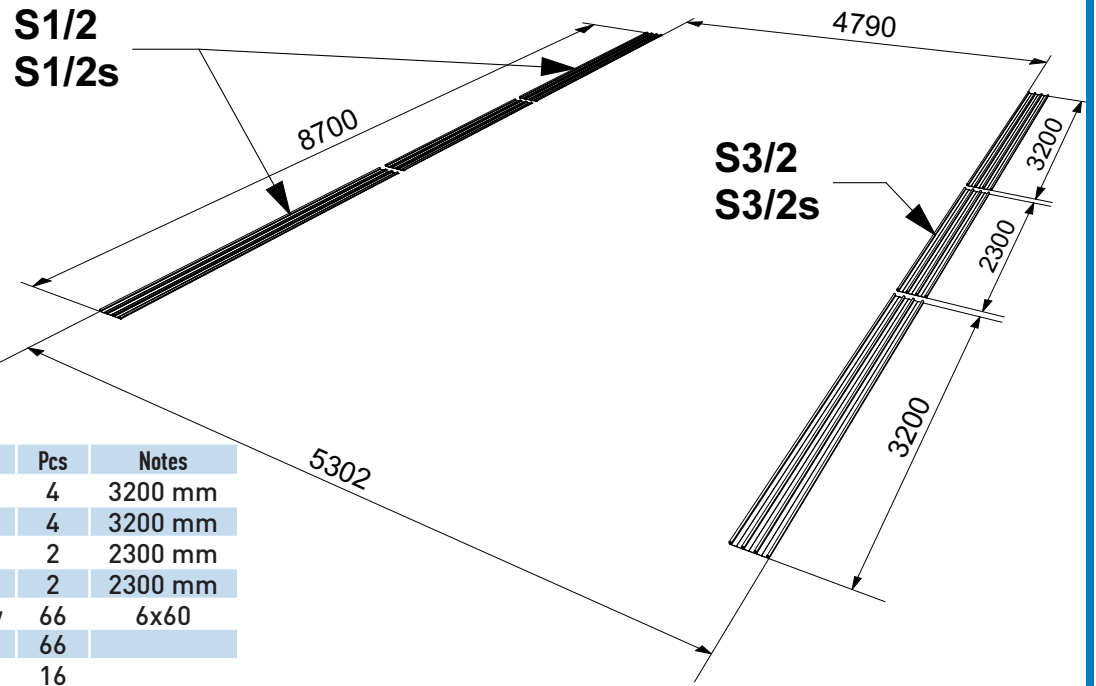

Item Nr.	Item name	Pcs	Notes
S1/2	Rail	4	3200 mm
S1/2s	Rail	4	3200 mm
S3/2	Rail	2	2300 mm
S3/2s	Rail	2	2300 mm
5	Pen head screw	66	6x60
6	Anchor	66	
14a	Rail joiner	16	

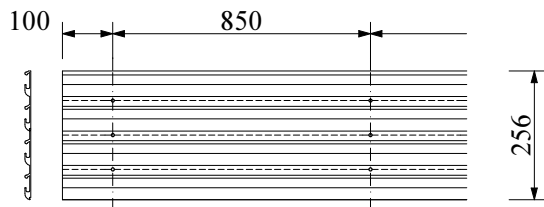

Suggested spots for holes on the rail (depending on the ground surface)

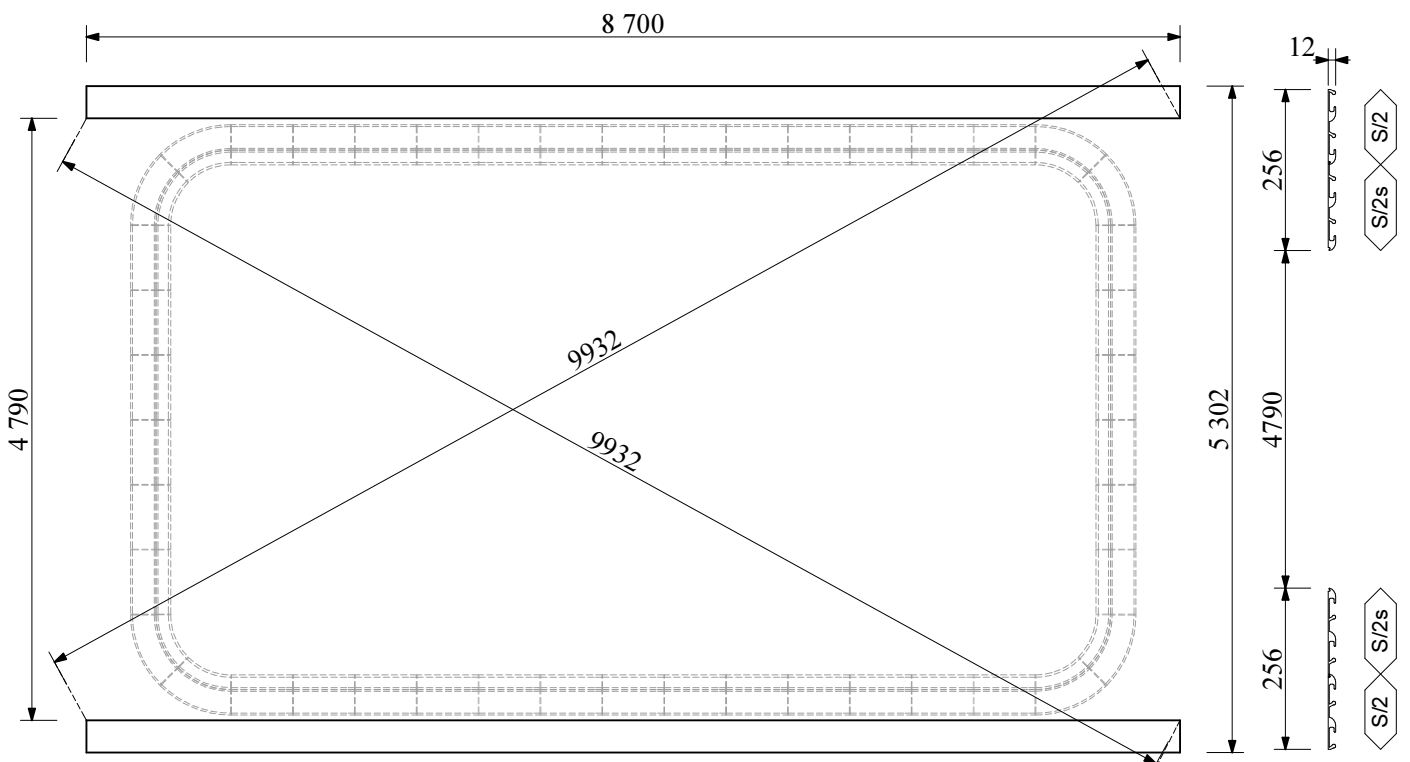
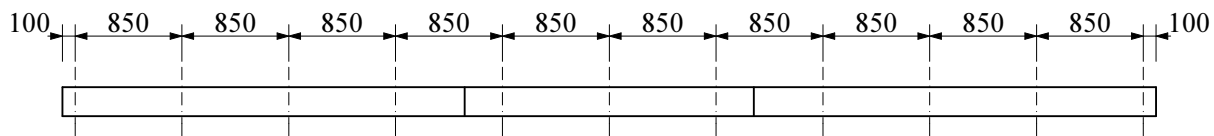

Rail placement

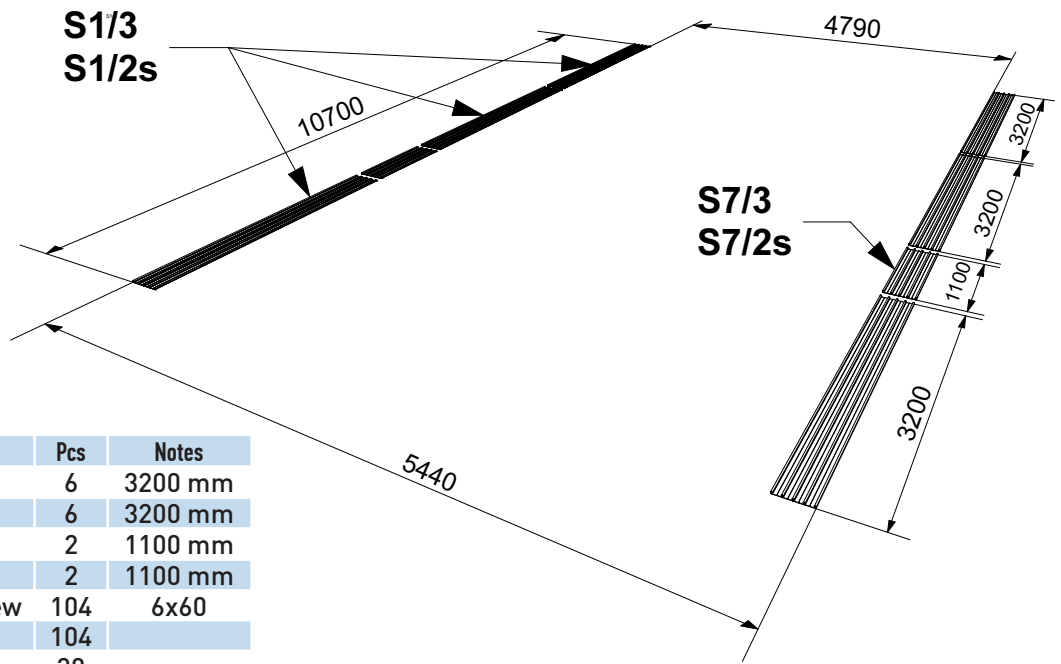

Item Nr.	Item name	Pcs	Notes
S1/3	Rail	6	3200 mm
S1/2s	Rail	6	3200 mm
S7/3	Rail	2	1100 mm
S7/2s	Rail	2	1100 mm
5	Pen head screw	104	6x60
6	Anchor	104	
14a	Rail joiner	30	

Suggested spots for holes on the rail (depending on the ground surface)

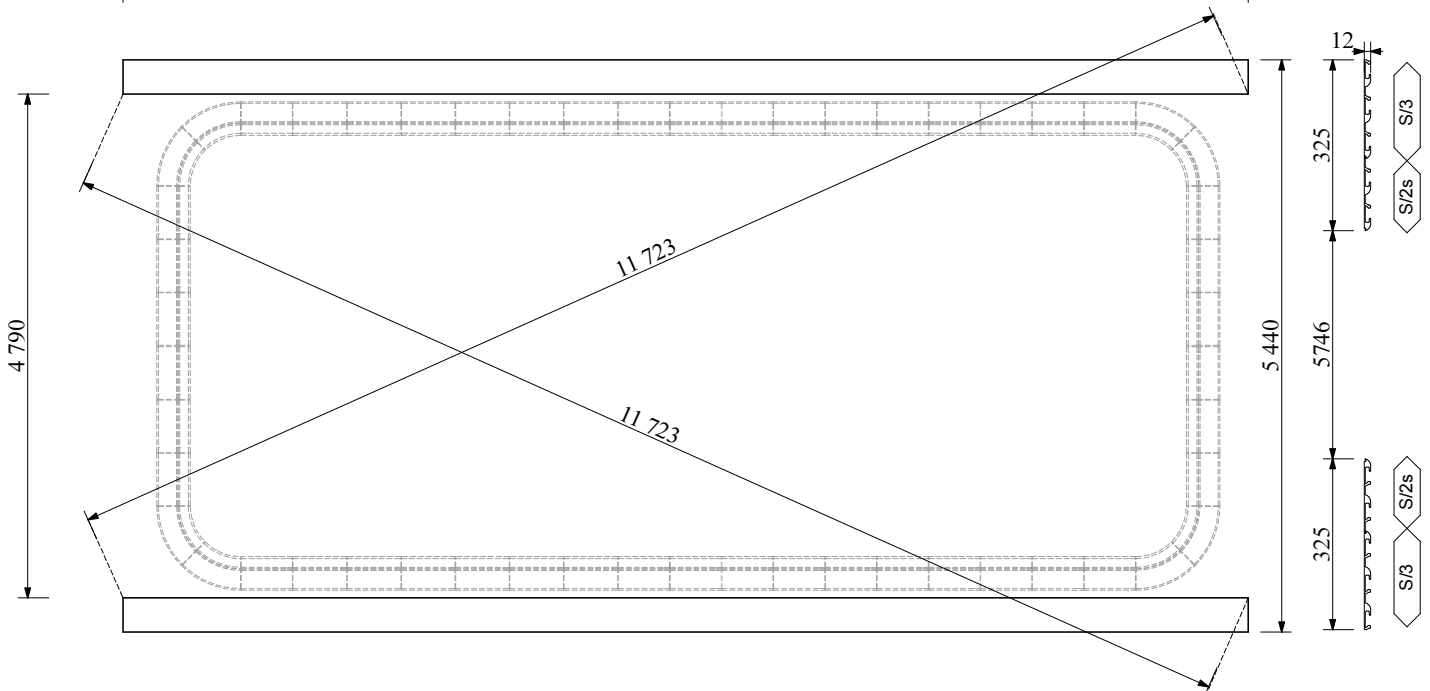
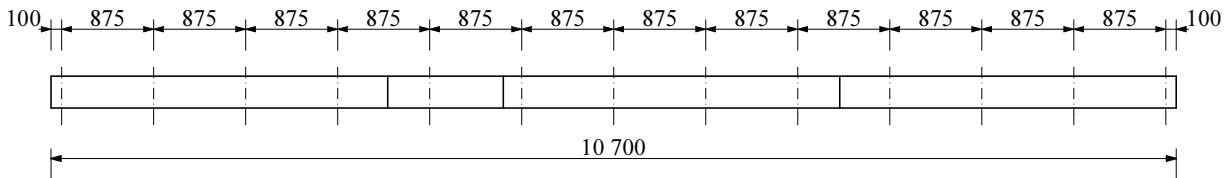
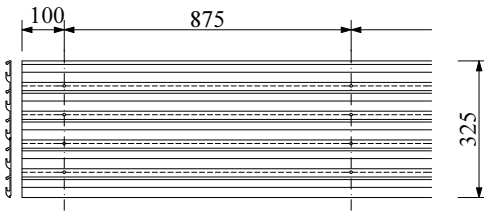

Rail placement

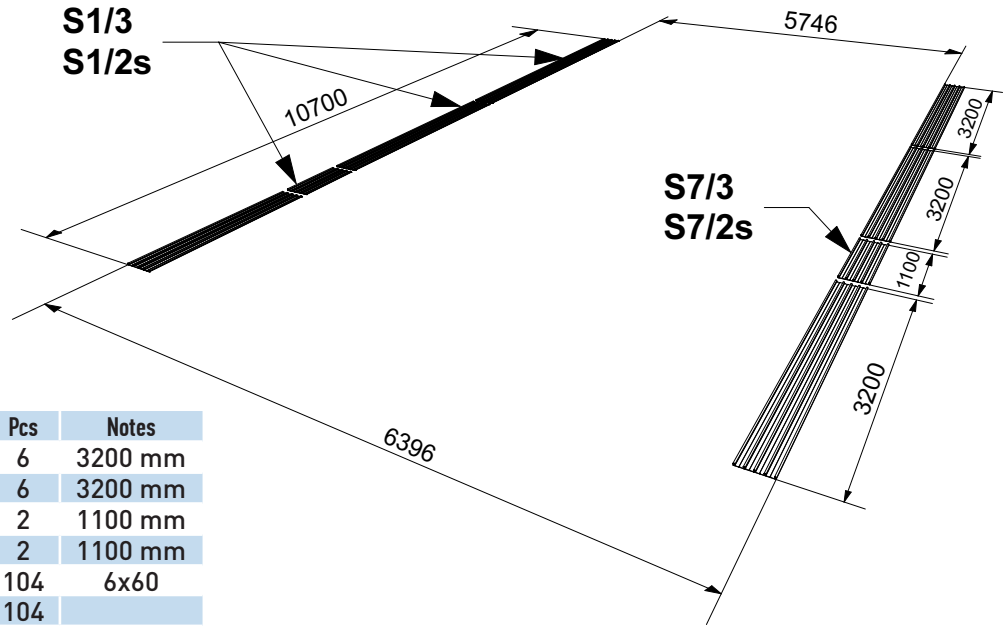

Item Nr.	Item name	Pcs	Notes
S1/3	Rail	6	3200 mm
S1/2s	Rail	6	3200 mm
S7/3	Rail	2	1100 mm
S7/2s	Rail	2	1100 mm
5	Pen head screw	104	6x60
6	Anchor	104	
14a	Rail joiner	30	

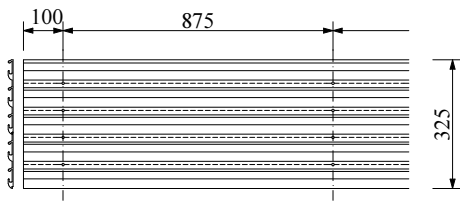

Suggested spots for holes on the rail
(depending on the ground surface)

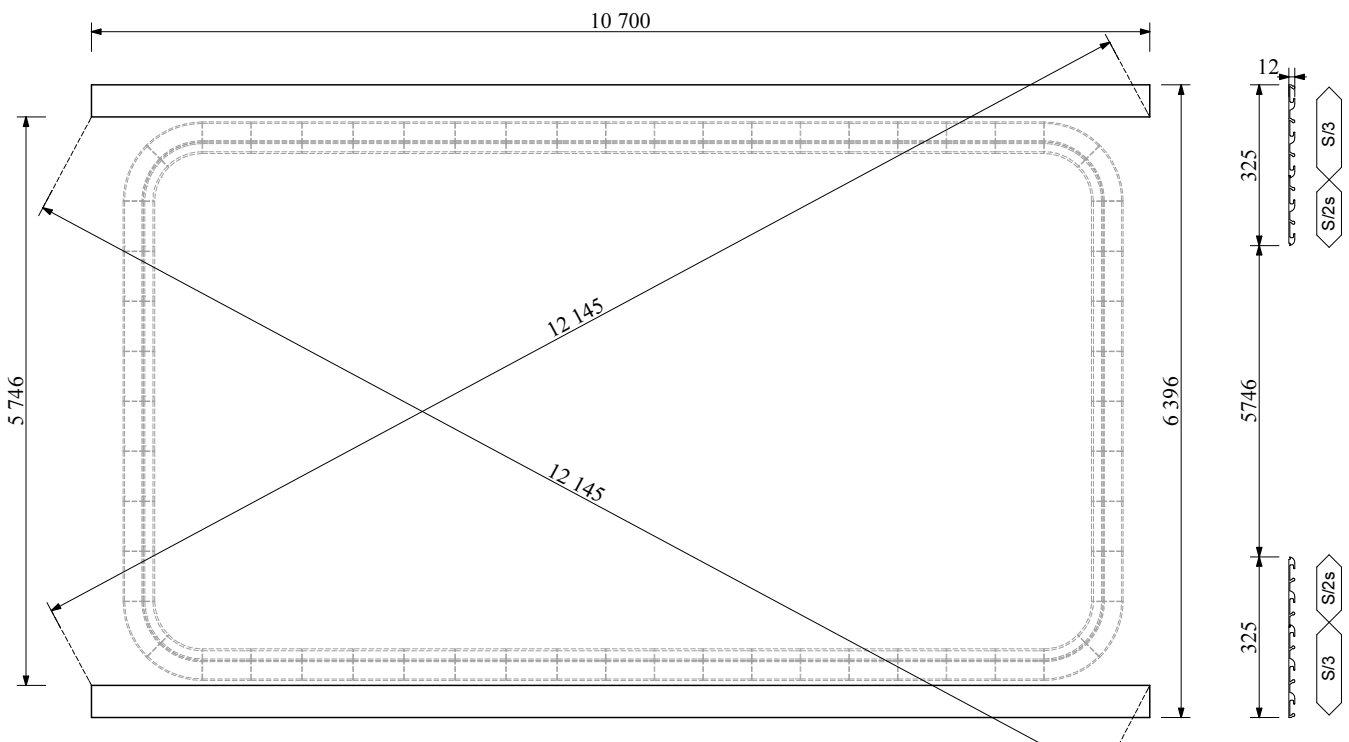
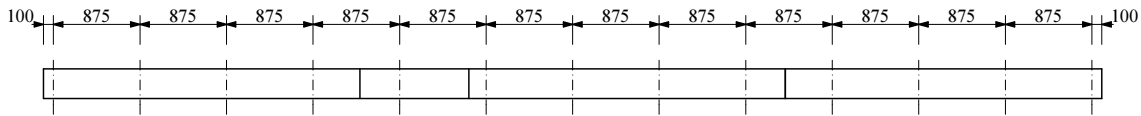

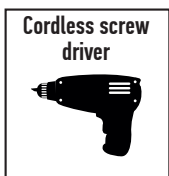
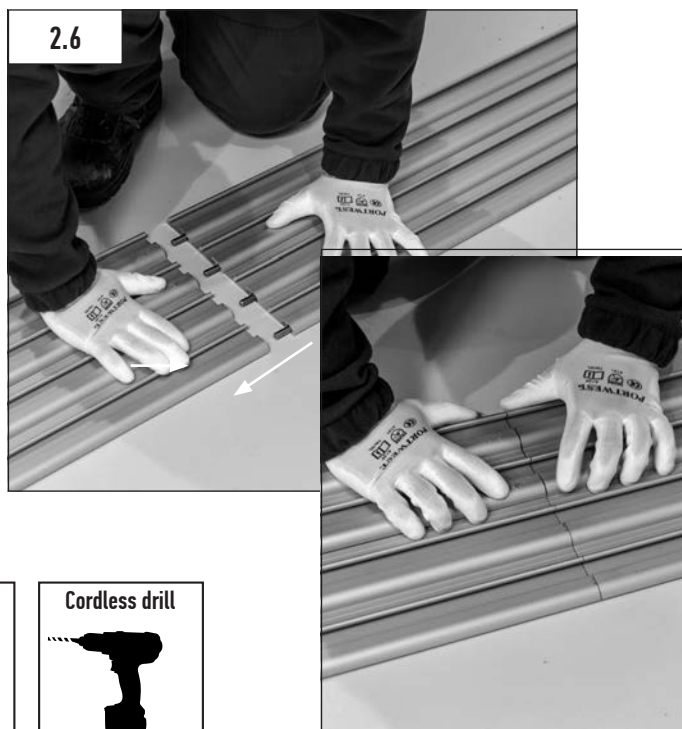
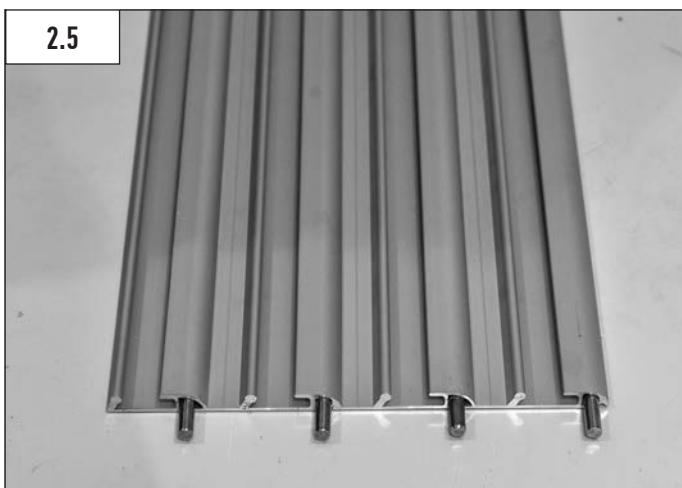
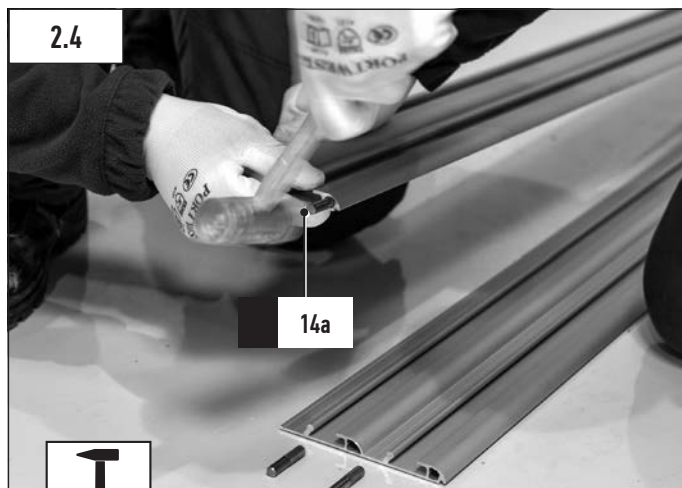
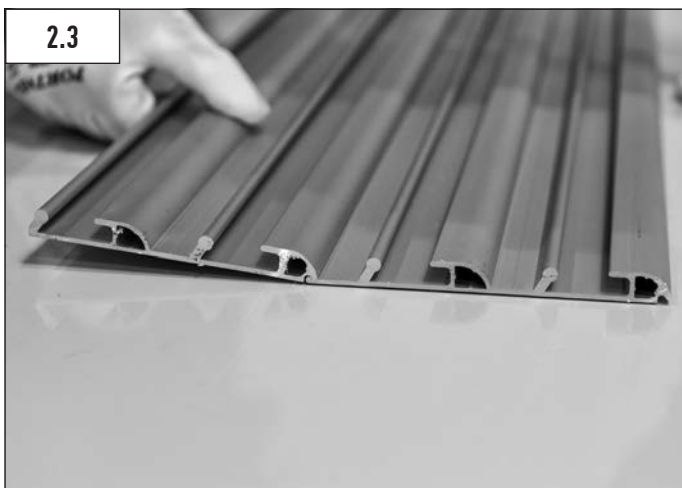
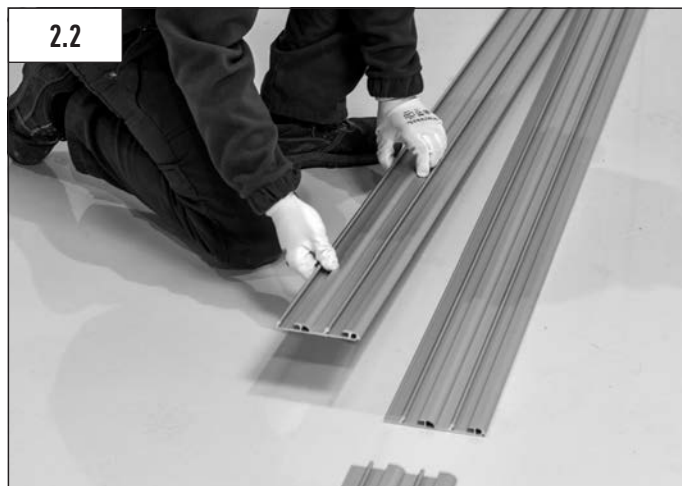

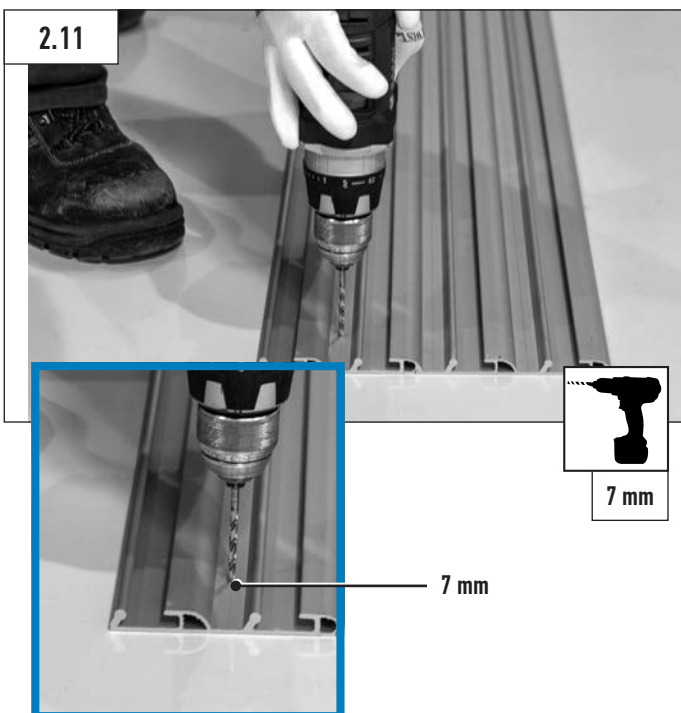
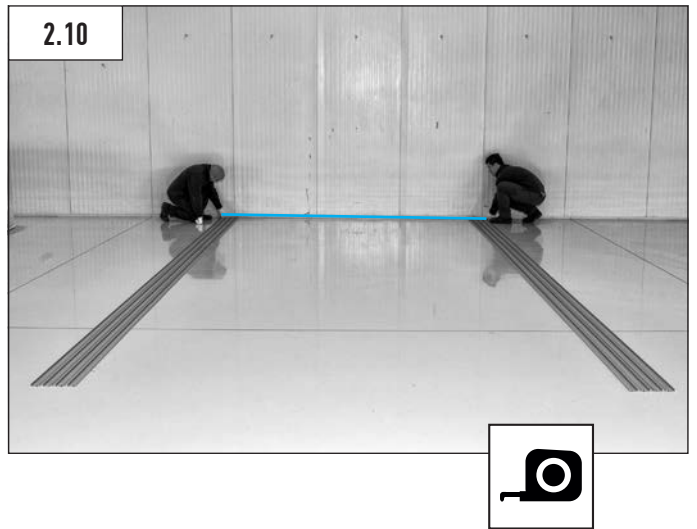
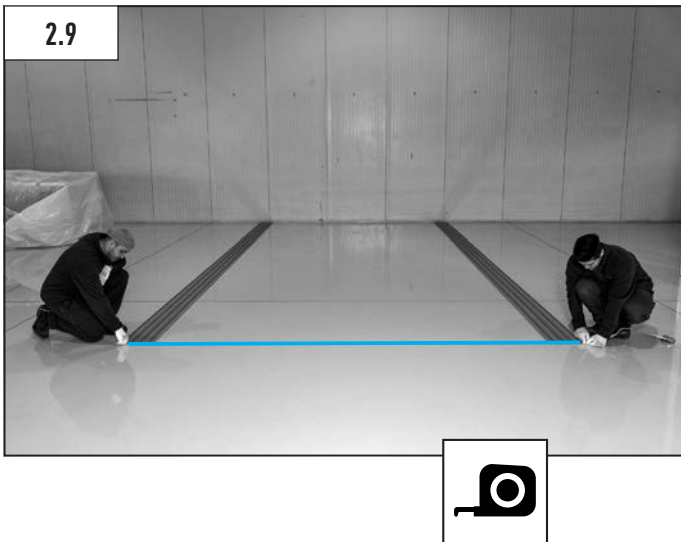
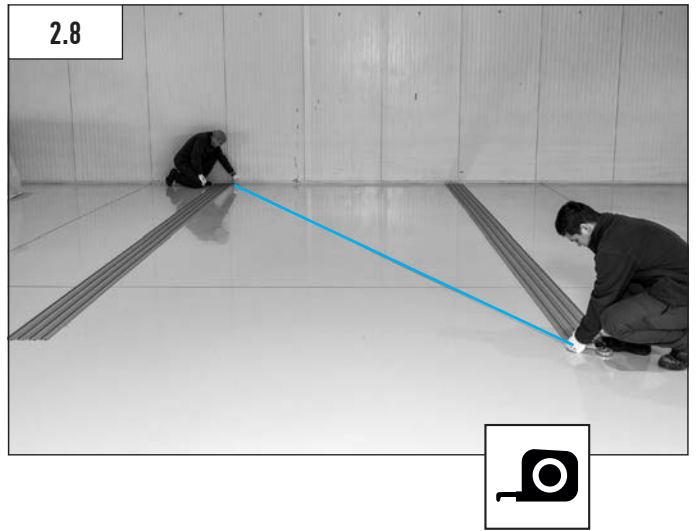
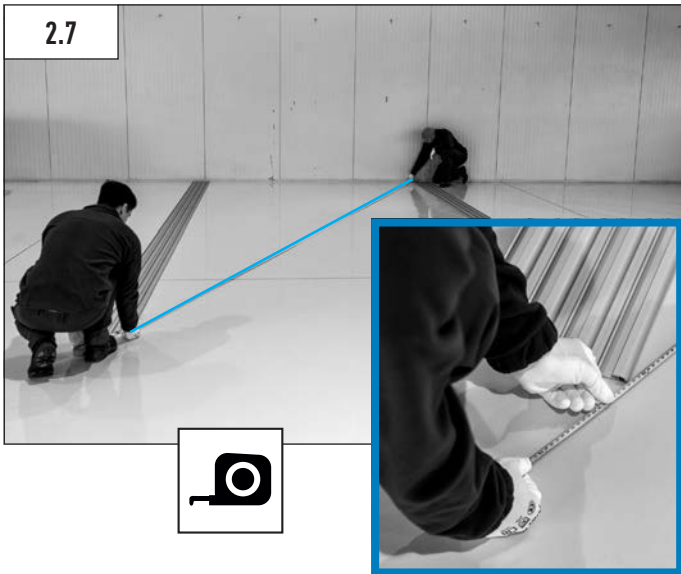

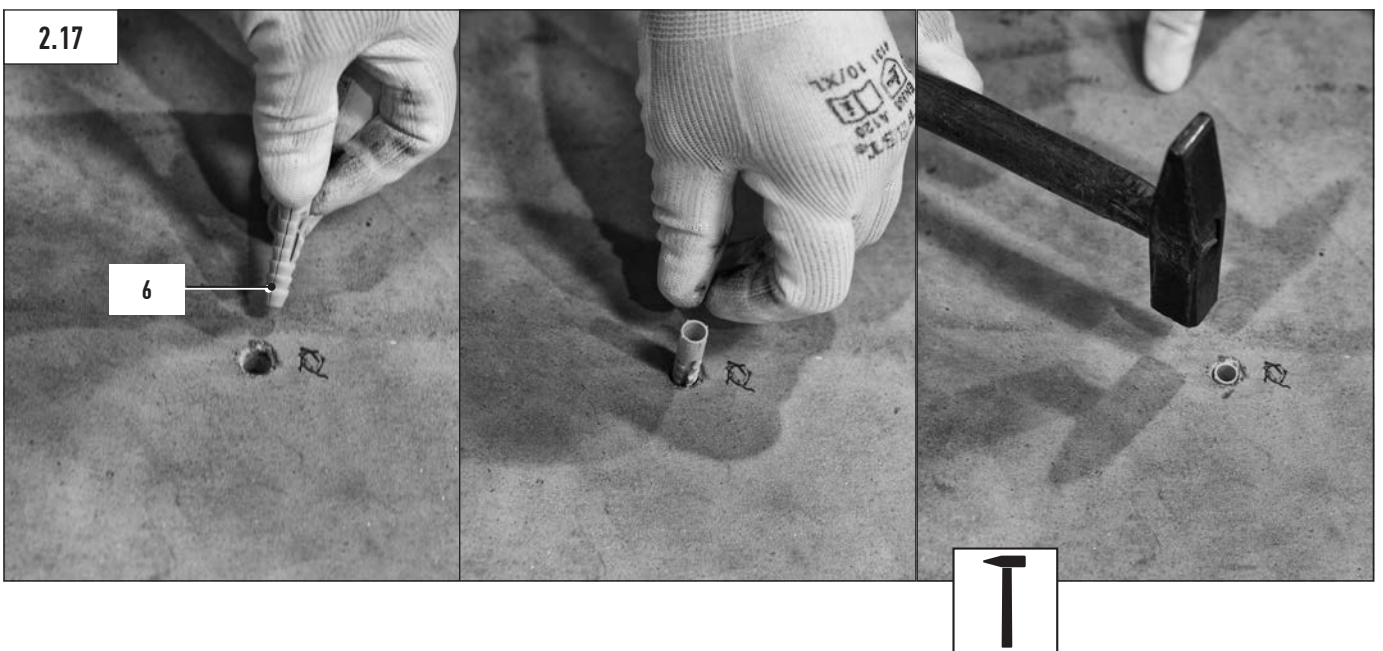
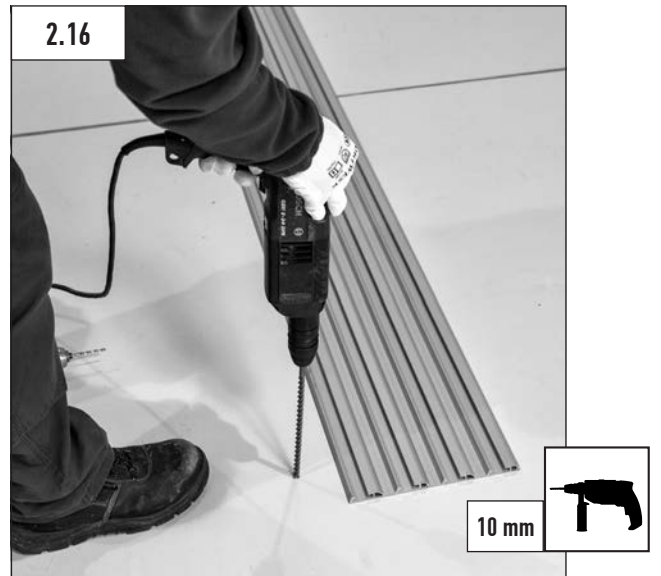
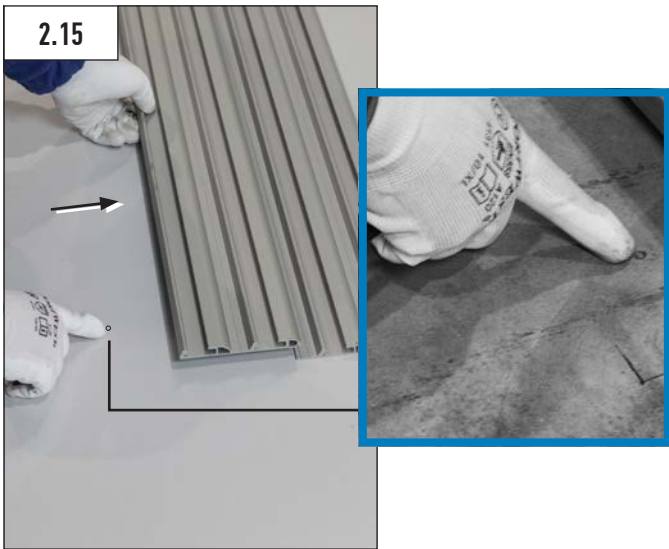
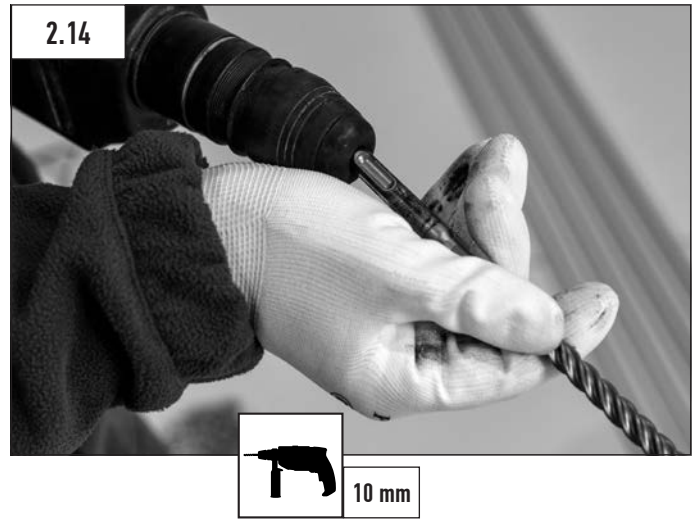
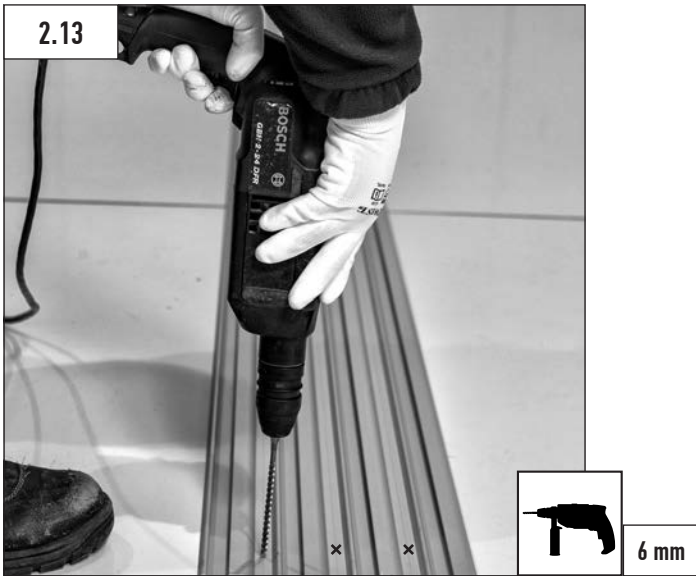

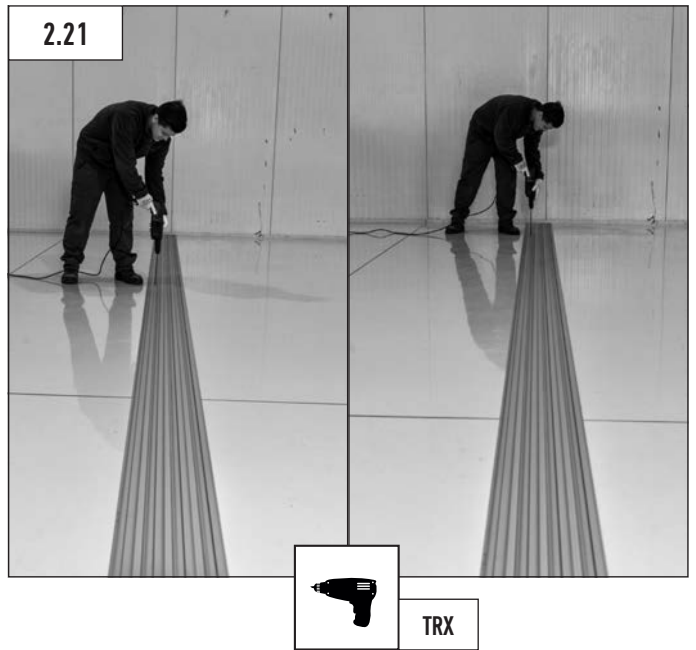
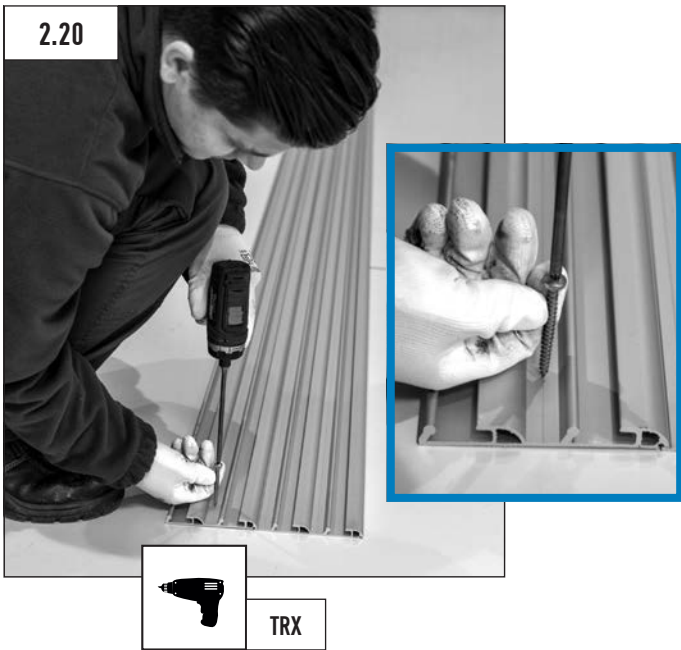
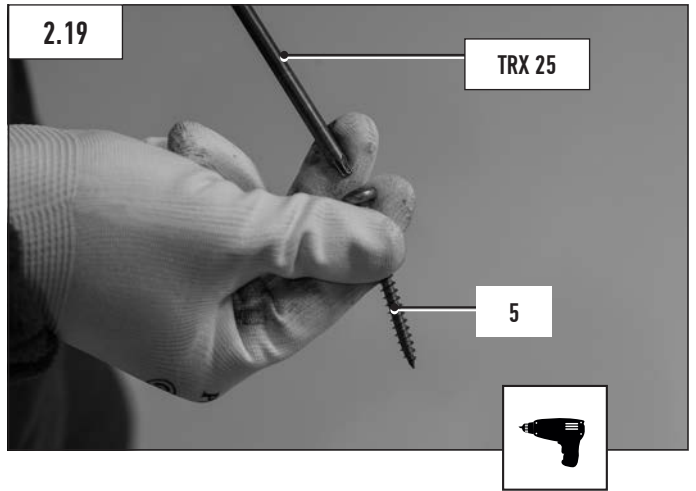

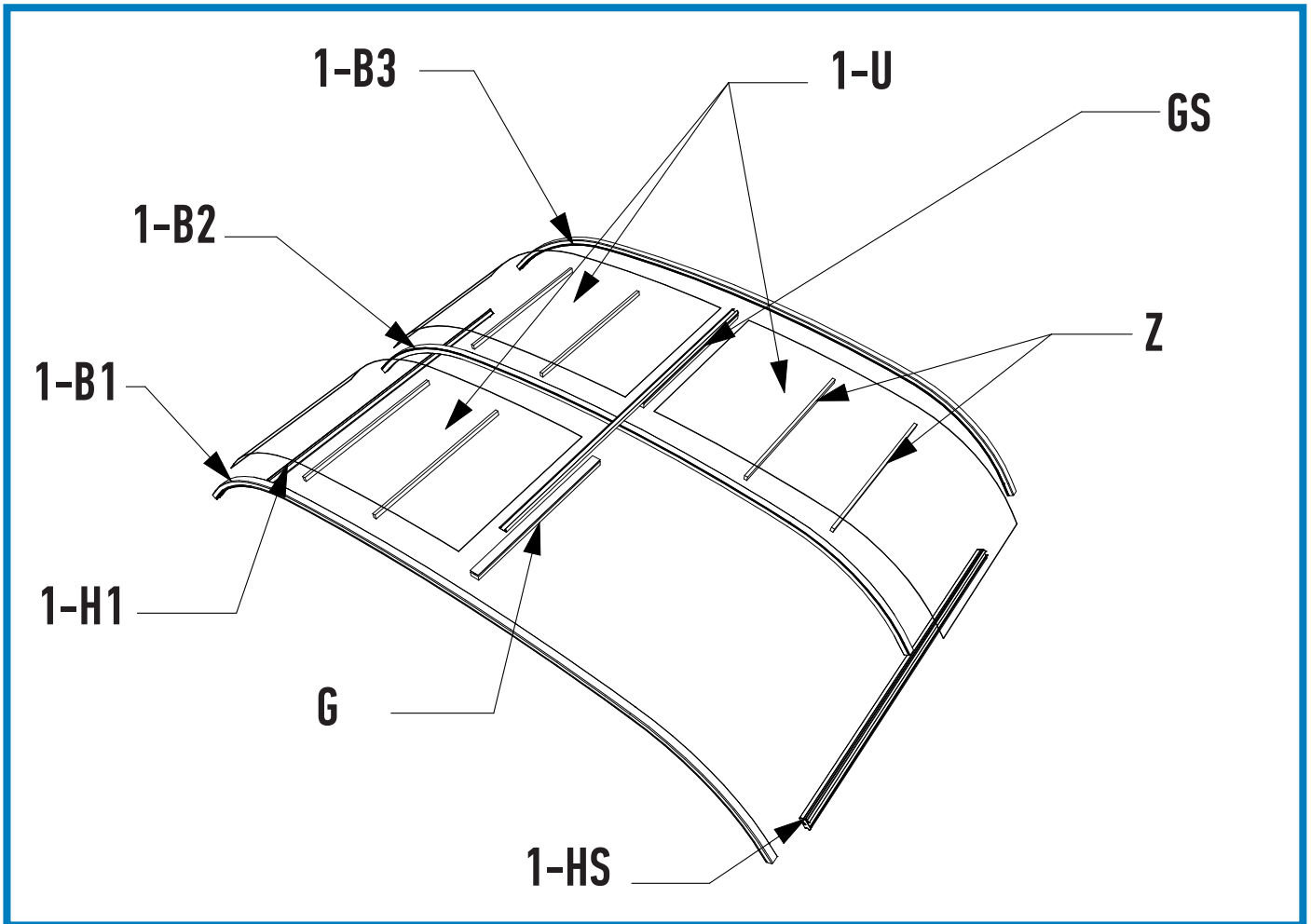

Item nr.	Item name	Pcs	Pcs	Notes
1-B1	1. arch	1	1	
1-B2	2. arch	1	1	
1-B3	3. arch	1	1	
1-H	Receiver profile	1	1	
1-HS	Receiver profile with rail	1	1	
1-U	PC Clear plate / PC Thermo plate	3	3	
Z	Linking hollow section	6	9	
G	Linking profile	1	1	
GS	Linking profile with rail	1	1	
1	Pen head torx screw	12	12	4,8 x 50
4	Square lock	1	1	
9	Receiver profile cap (L -R)	2	2	1 right + 1 left
10	Hidden arrest	2	2	1 right + 1 left
18	Buffer plate	2	2	1 right + 1 left
22	Outside rubber (double)*			

* with PC Clear plate

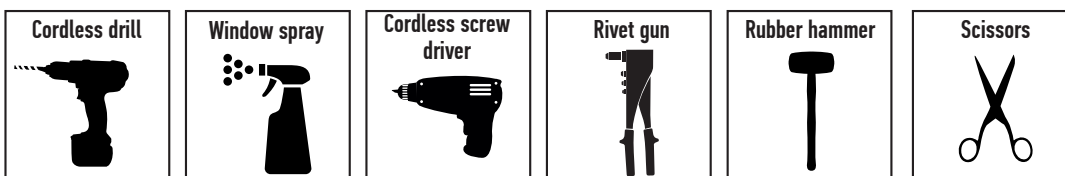

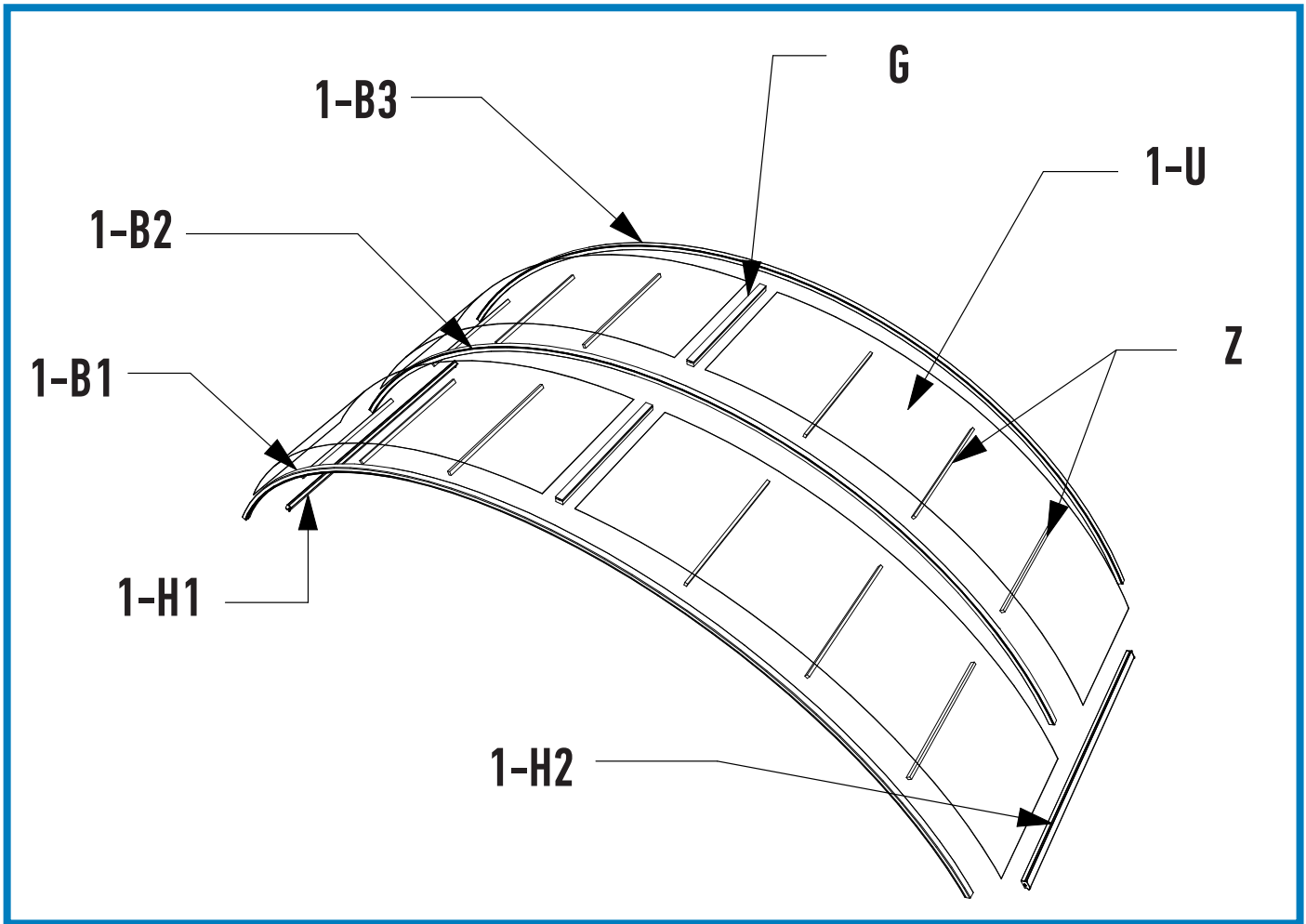

Item nr.	Item name				Notes
		M3	M4	M4/5	
1-B1	1. arch	1	1	1	
1-B2	2. arch	1	1	1	
1-B3	3. arch	1	1	1	
1-H1	Receiver profile - right	1	1	1	
1-H2	Receiver profile - left	1	1	1	
1-U	PC Clear plate / PC Thermo plate	2	2	4	
Z	Linking hollow section	8	10	12	
G	Linking profile	-	-	2	
1	Pen head torx screw	12	12	12	4,8 x 50
4	Square lock	1	1	1	
10	Hidden arrest	2	2	2	1 right + 1 left
9	Receiver profile cap (L -R)	2	2	2	1 right + 1 left
18	Buffer plate	2	2	2	1 right + 1 left
22	Outside rubber (double)*				

*with PC Clear plate

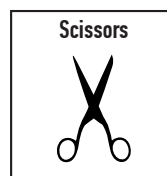
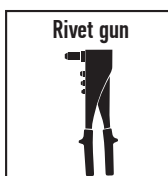

3 FIRST SEGMENT ASSEMBLY

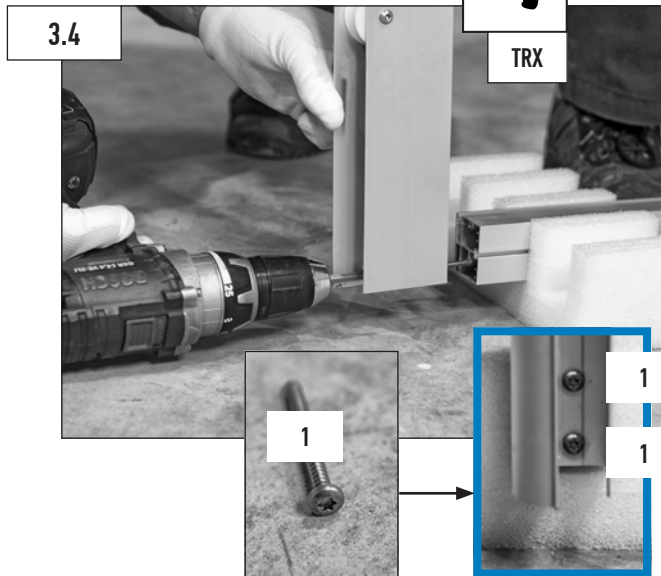
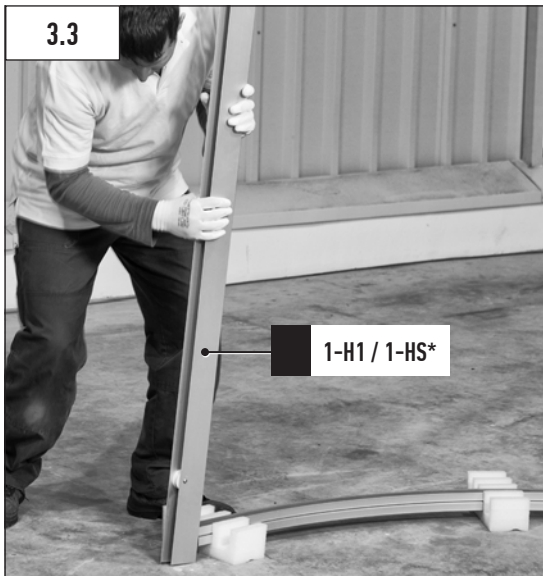
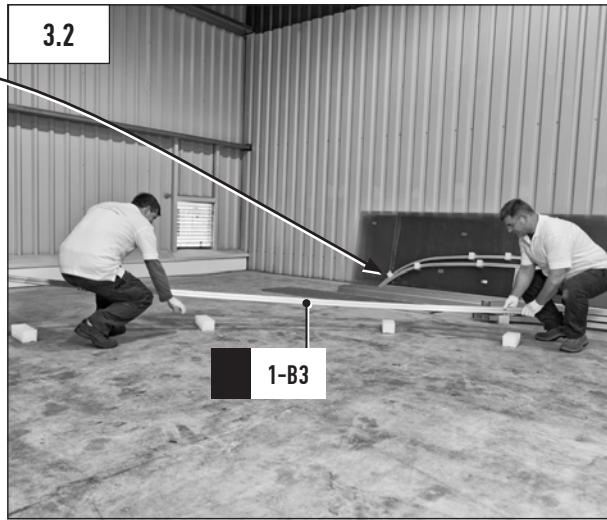
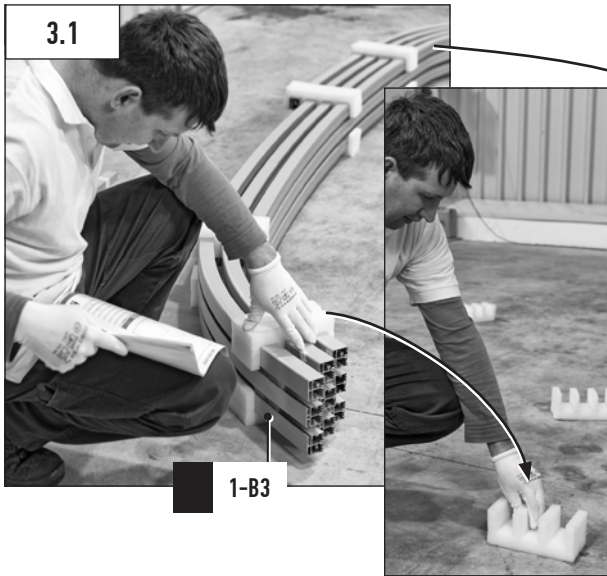

* 1-HS =
at the sliding door

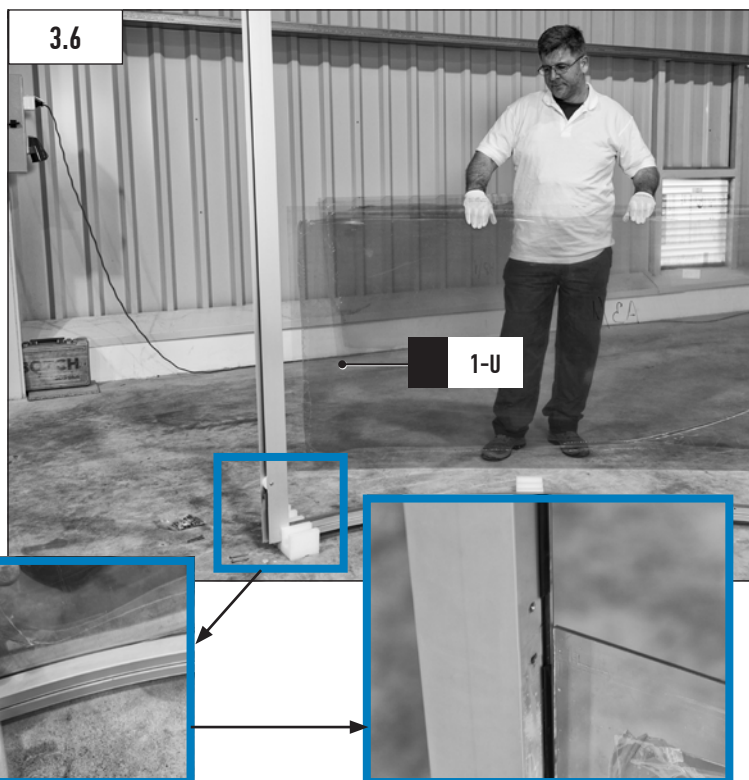

3 FIRST SEGMENT ASSEMBLY

*M5

** A3, A3/4, A4S, A4L, A4, A4/5, A5

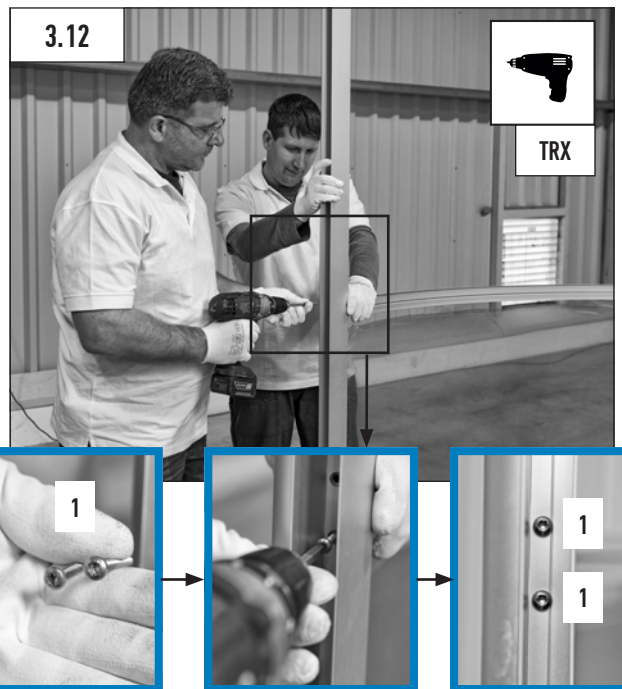
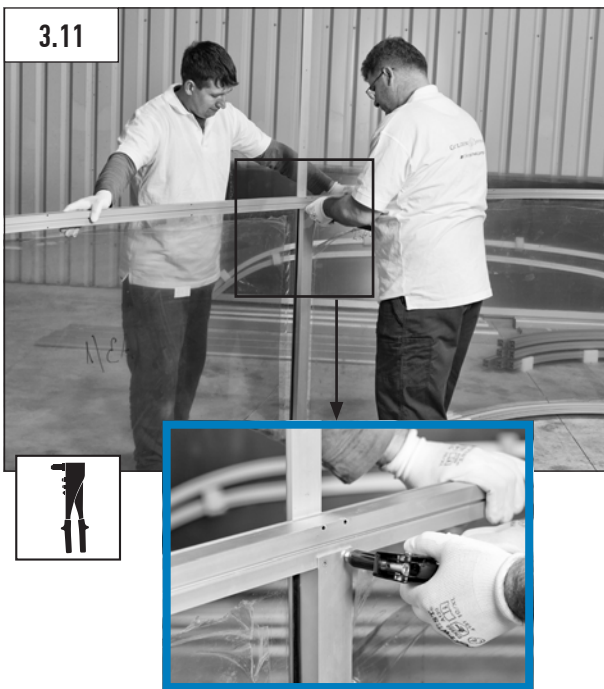
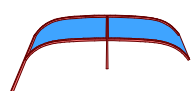
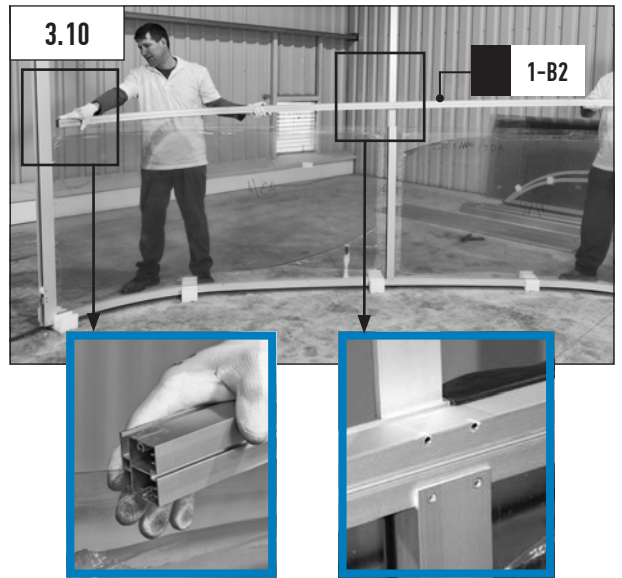
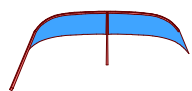
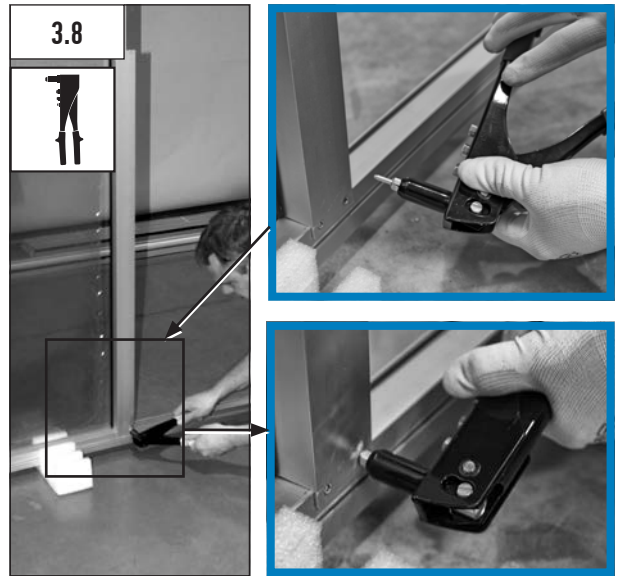
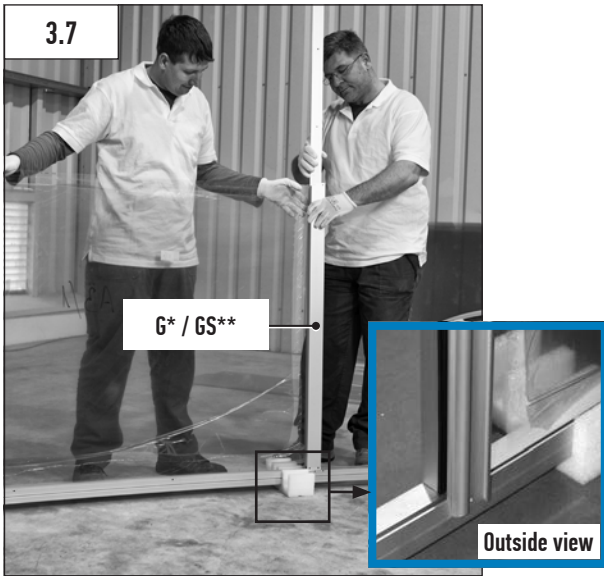
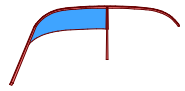

3 FIRST SEGMENT ASSEMBLY

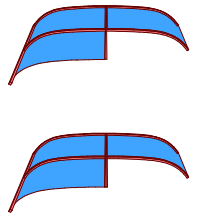
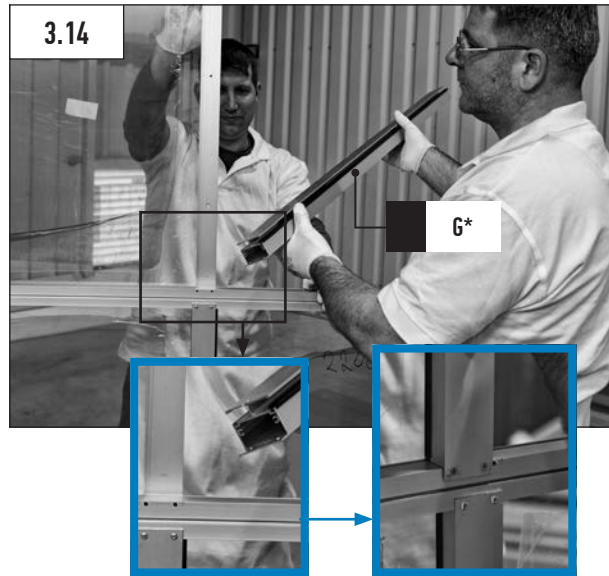
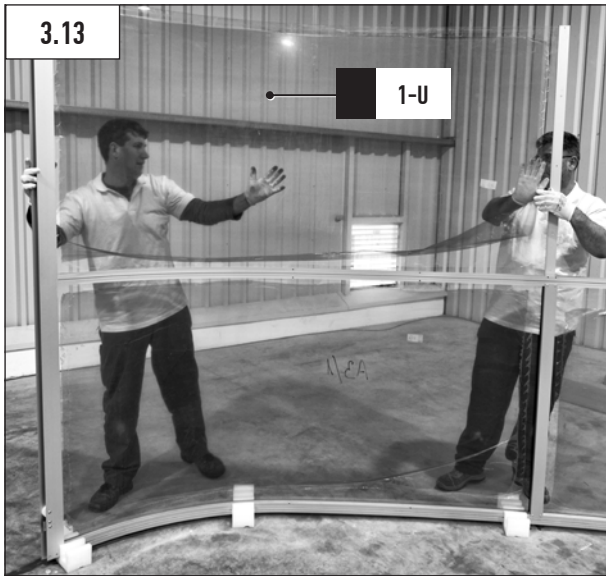

*A3, A3/4, A4S, A4L, A4, A4/5, A5, M5

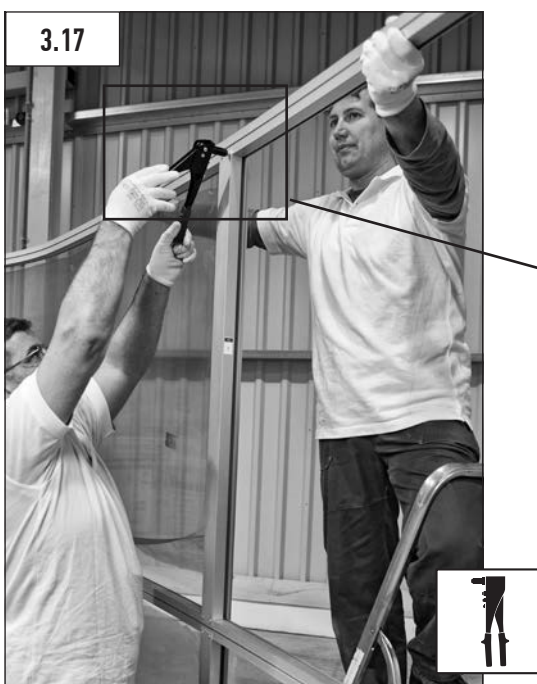
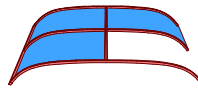
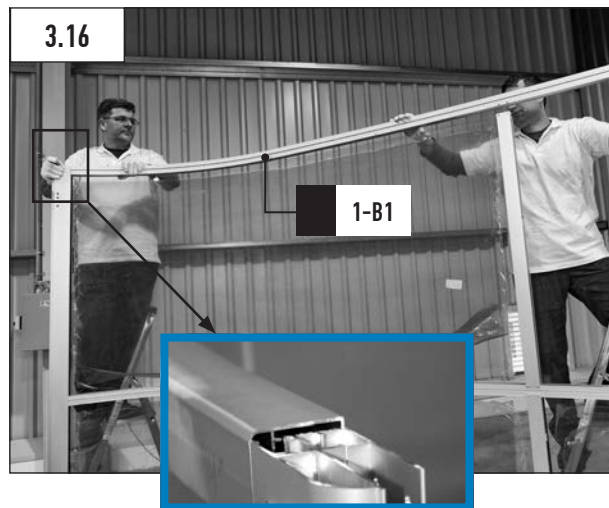

3 FIRST SEGMENT ASSEMBLY

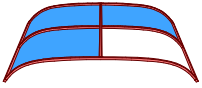
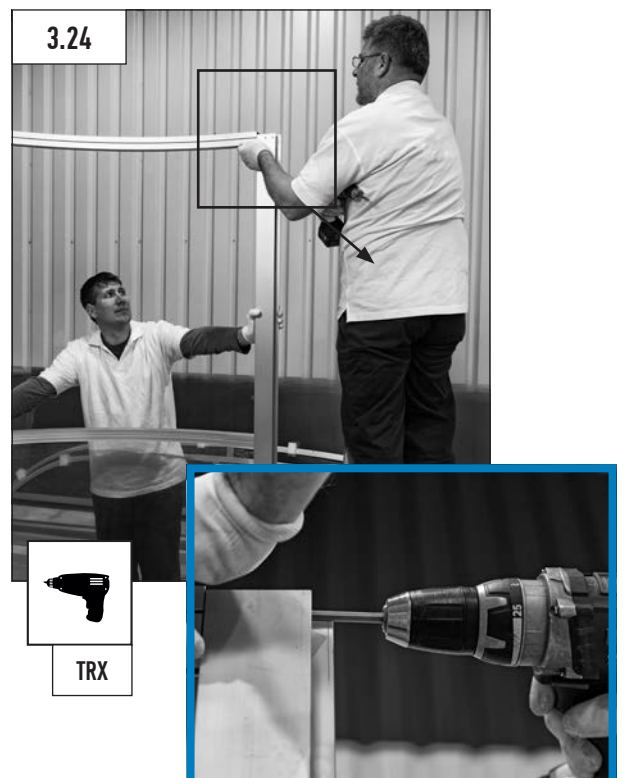
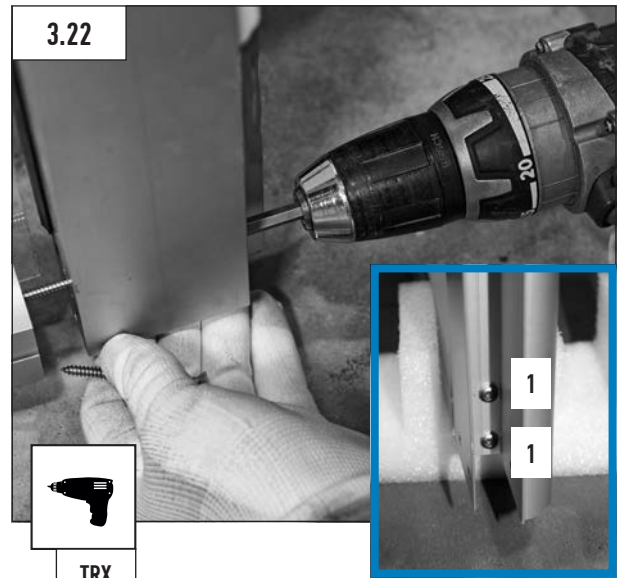
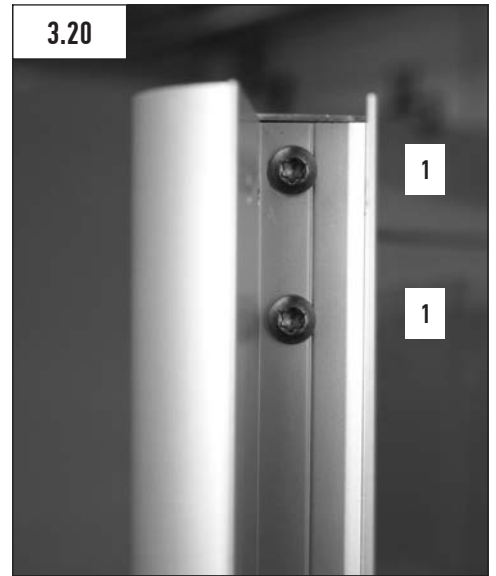
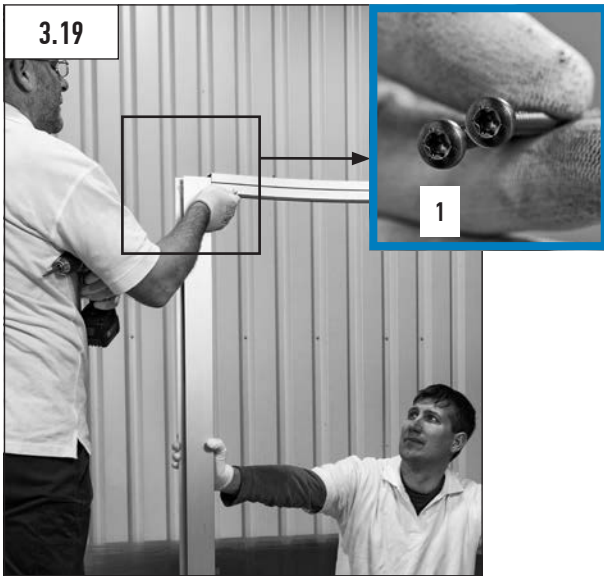

* A3, A3/4, A4S, A4L, A4, A4/5, A5 at the sliding door

**M3, M4, M4/5 M5

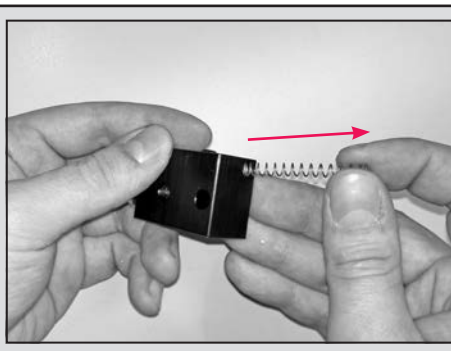
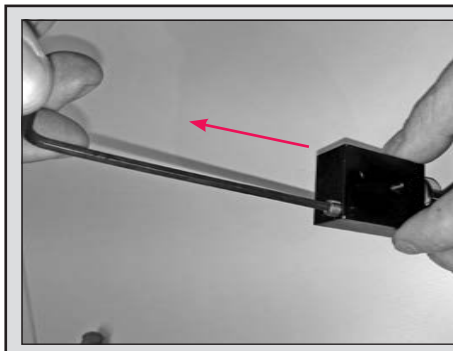

Optional:

By removing the screw and the spring on the key lock side, the pin will arrest automatically at the right position when closing the segment.

The opposite side should be arrested manually when closing the segment.

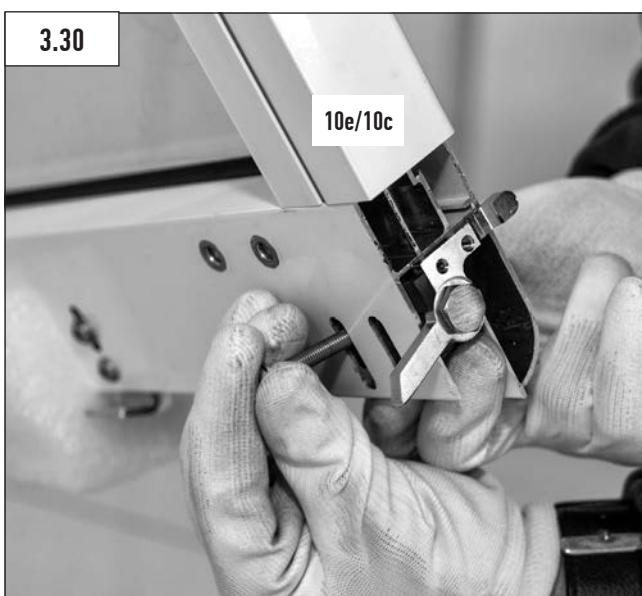
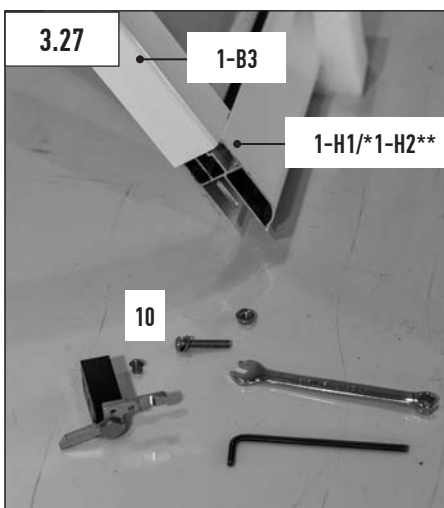

3 FIRST SEGMENT ASSEMBLY

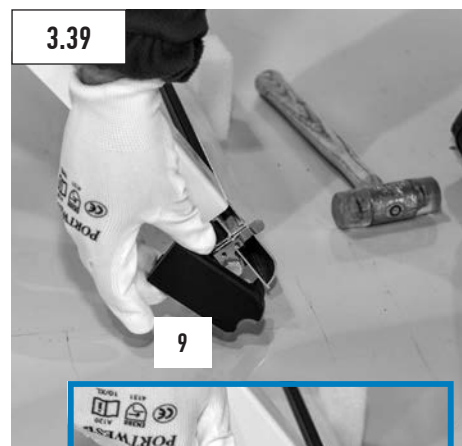
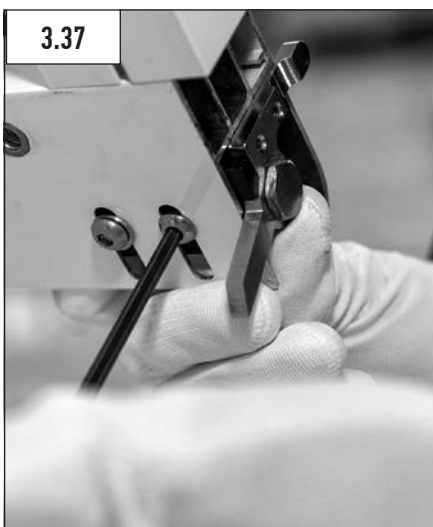
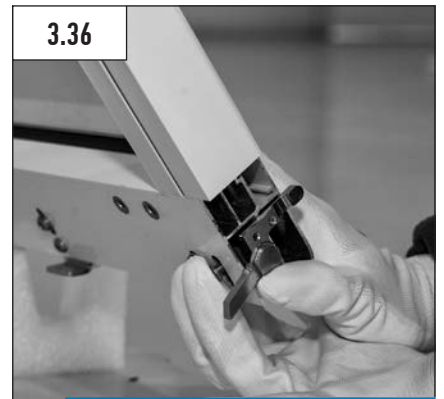
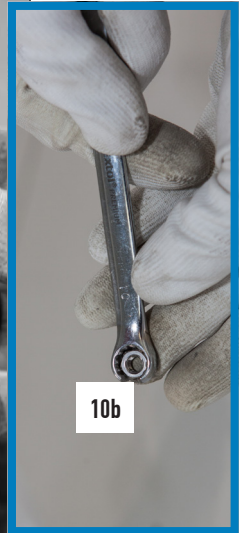
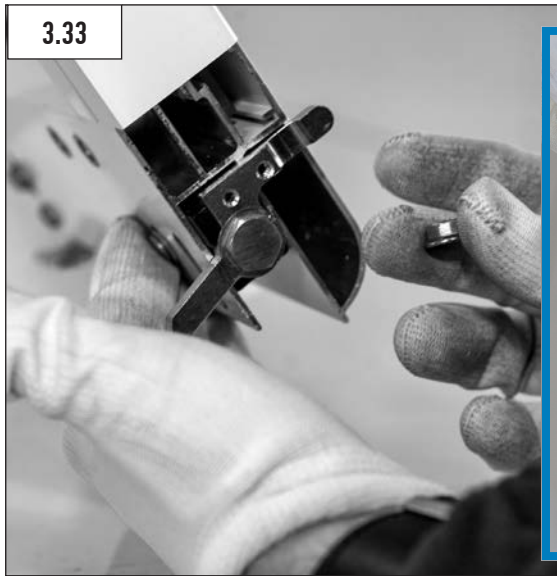

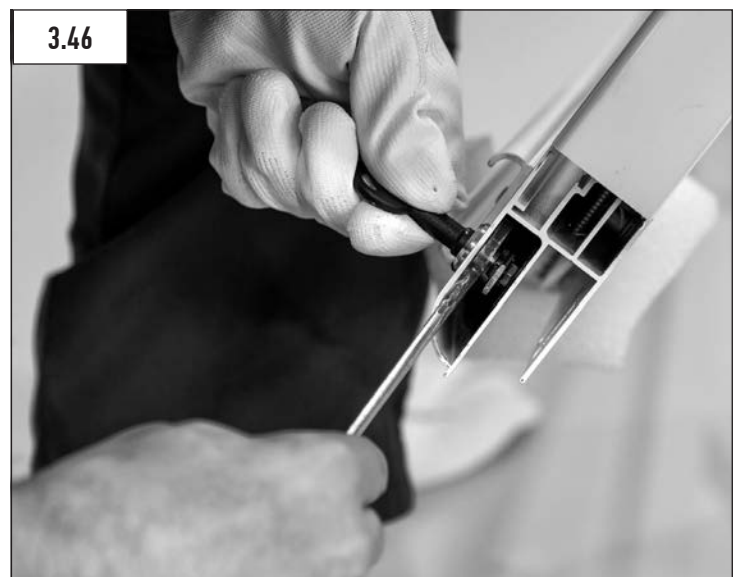
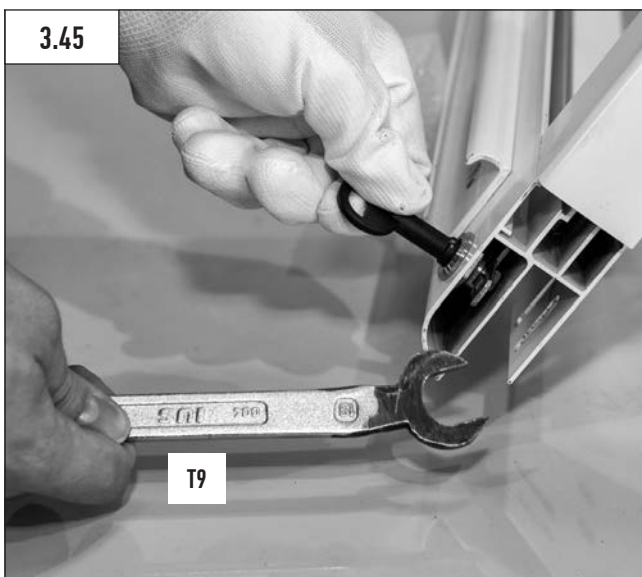
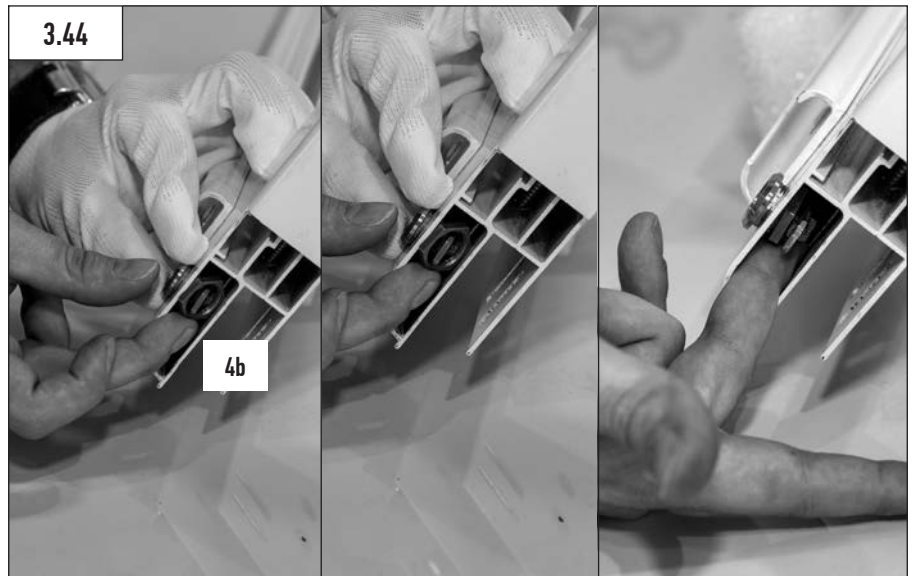
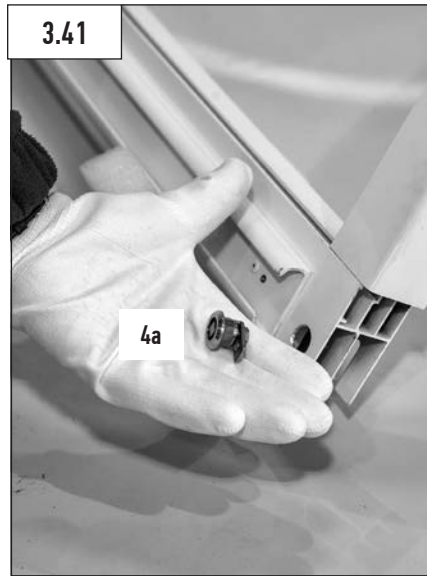
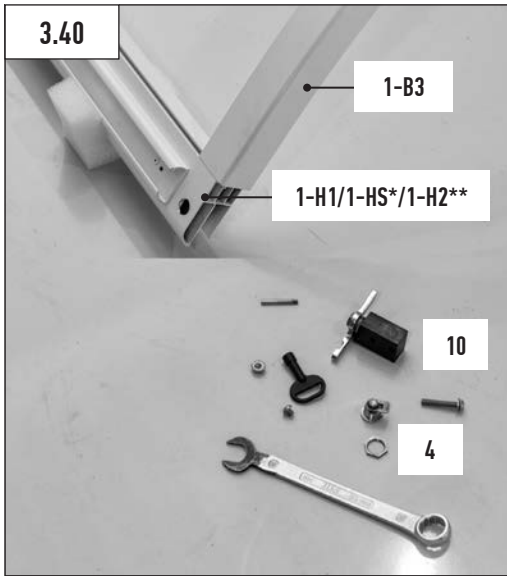

* A3, A3/4, A4S,
A4L, A4, A4/5, A5
at the sliding door

**M3, M4, M4/5 M5

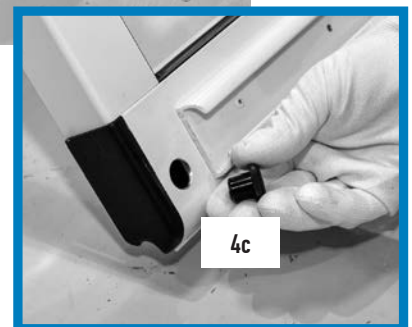
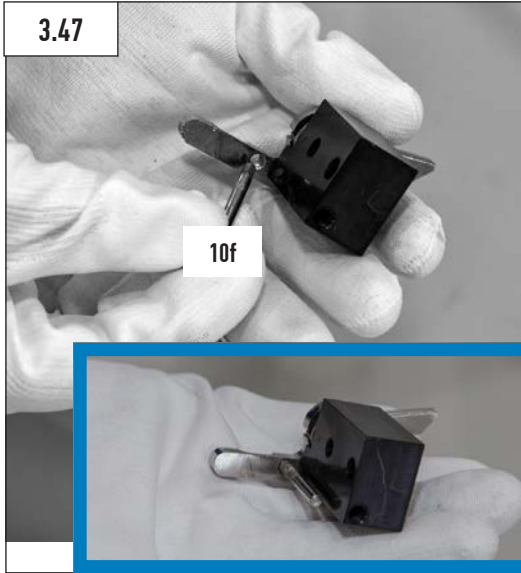

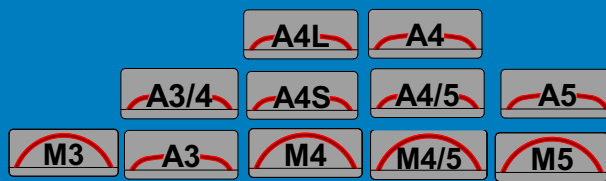
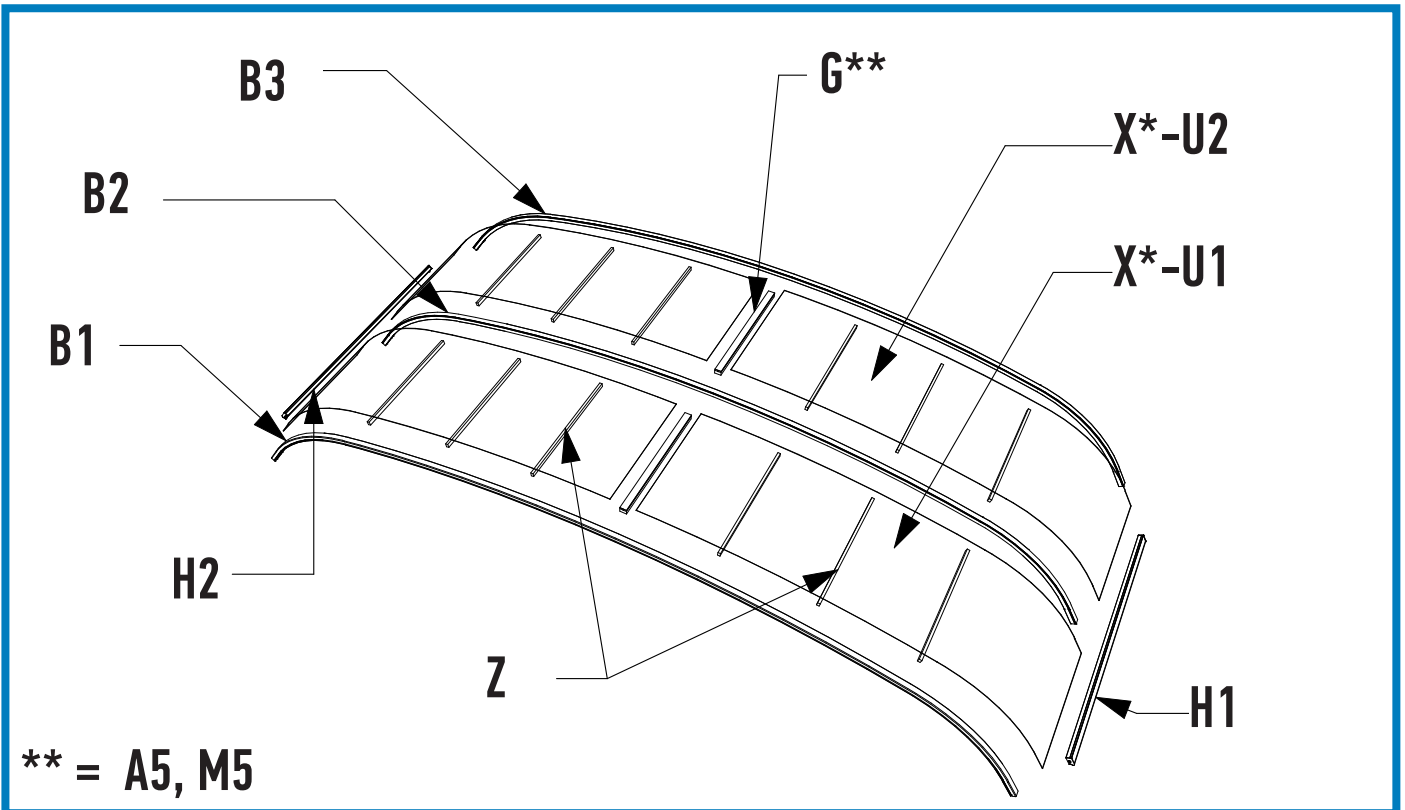

Item nr.	Item name	Pcs	Pcs	Pcs	Notes
x*-B1	1. arch	1	1	1	
x*-B2	2. arch	1	1	1	
x*-B3	3. arch	1	1	1	
H1	Receiver profile - right	1	1	1	left
H2	Receiver profile - left	1	1	1	right
X*-U1	PC Clear plate / PC Thermo plate	1	1	2	
X*-U2	PC Clear plate / PC Thermo plate	1	1	2	
Z	Linking hollow section	8	10	10	
G	Linking profile	-	-	2	
1	Pen head torx screw	12	12	12	4,8 x 50
12	Rocker lever	1	1	1	1
18	Buffer plate	1	1	1	1 left + 1 right
9	Receiver profile cap	1	1	1	1 left + 1 right
11	Receiver profile cap	1	1	1	1 left + 1 right
22	Outside rubber (double)***				

*** with PC Clear plate

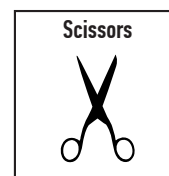
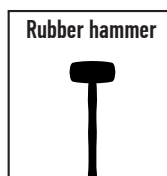

4 INTERMEDIATE SEGMENT ASSEMBLY

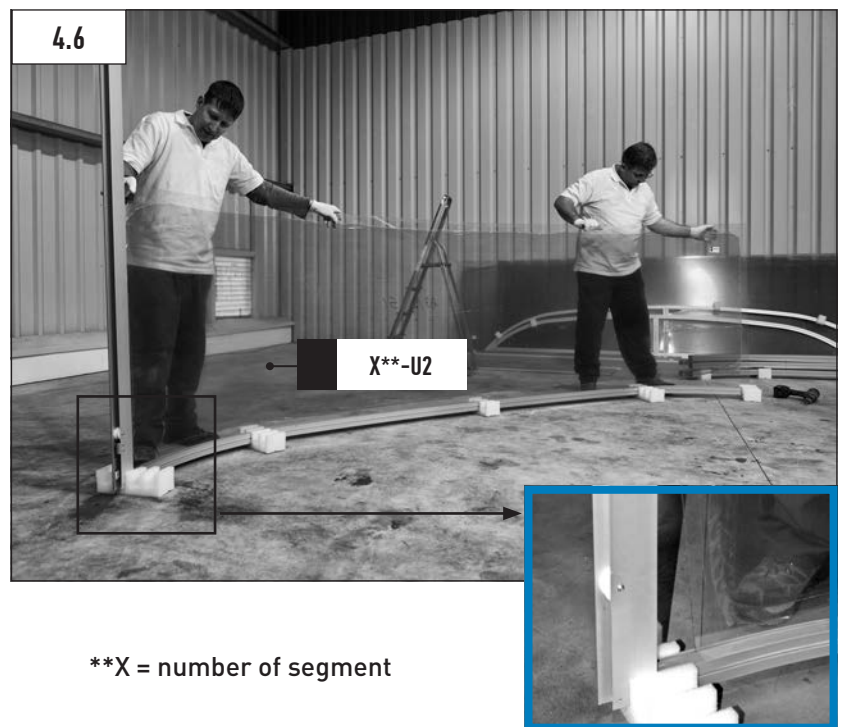
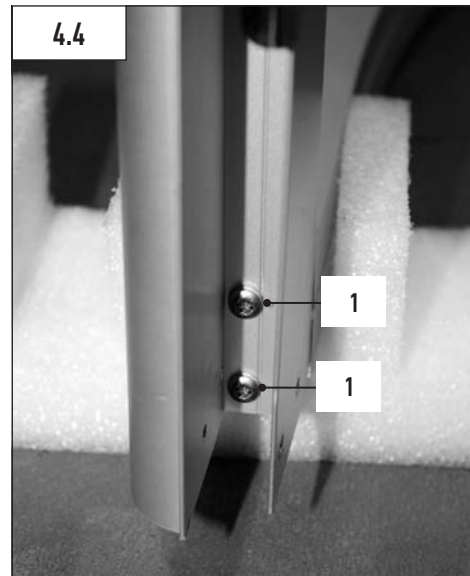
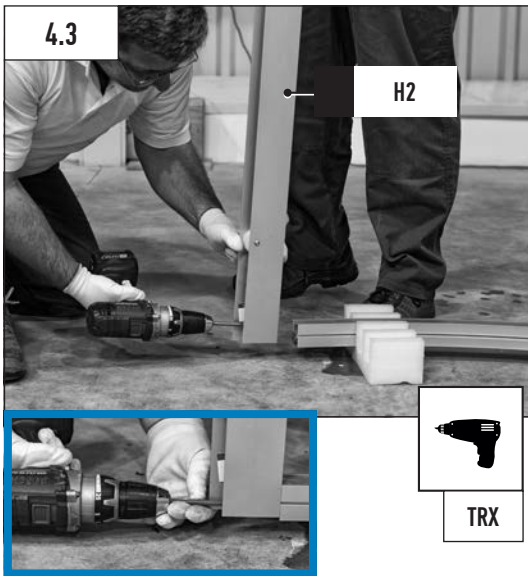
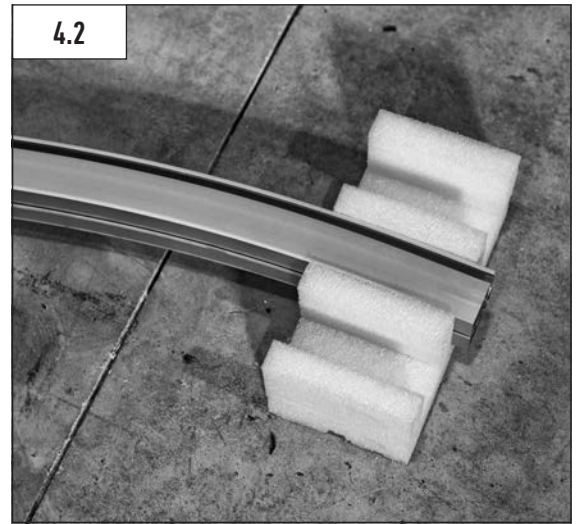
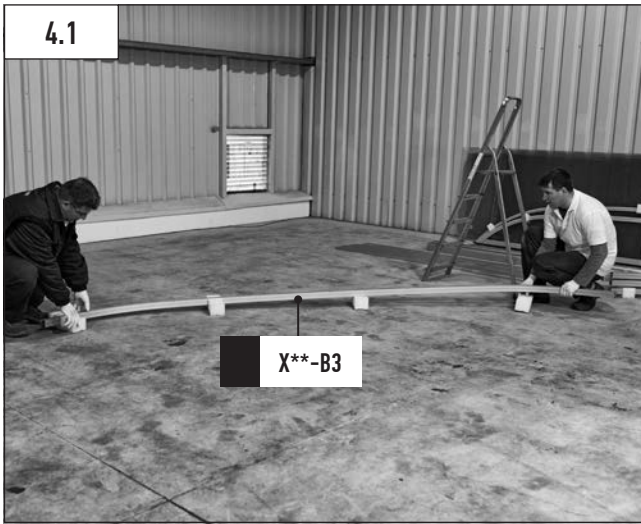

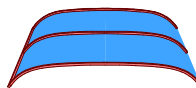
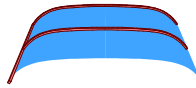
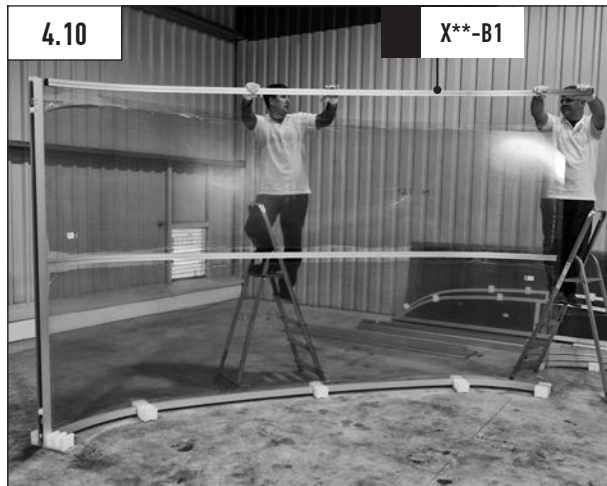
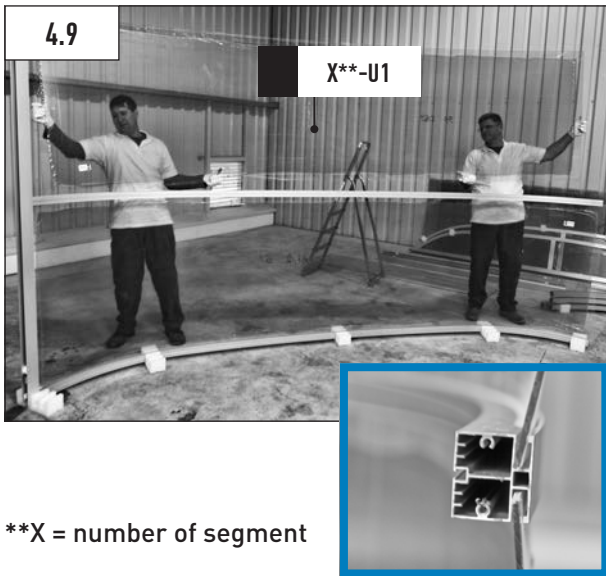
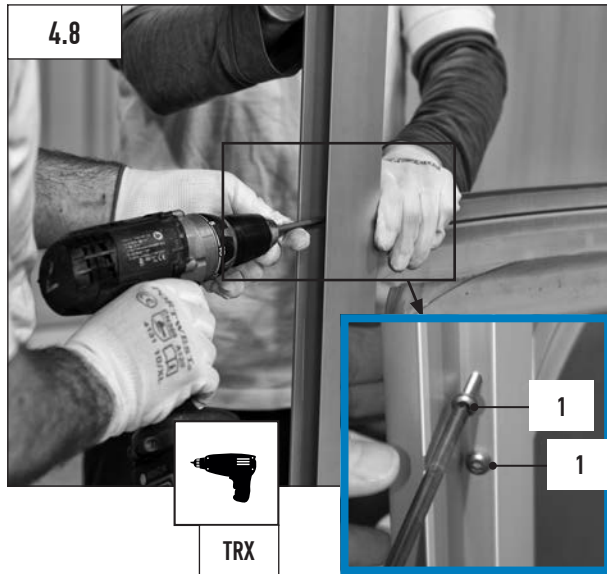
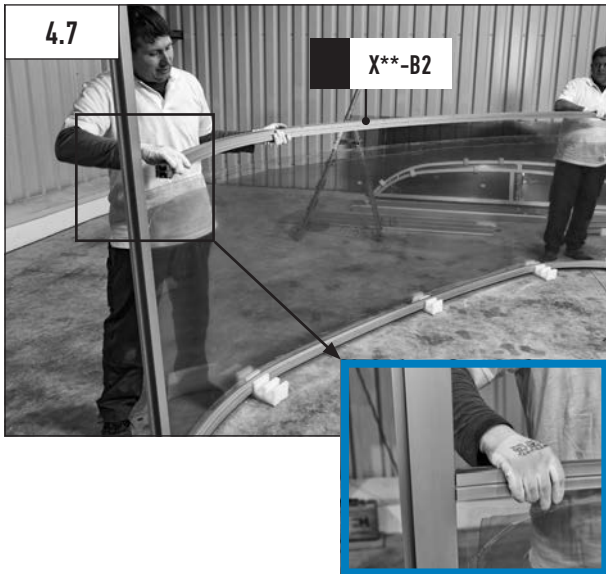

**X = number of segment

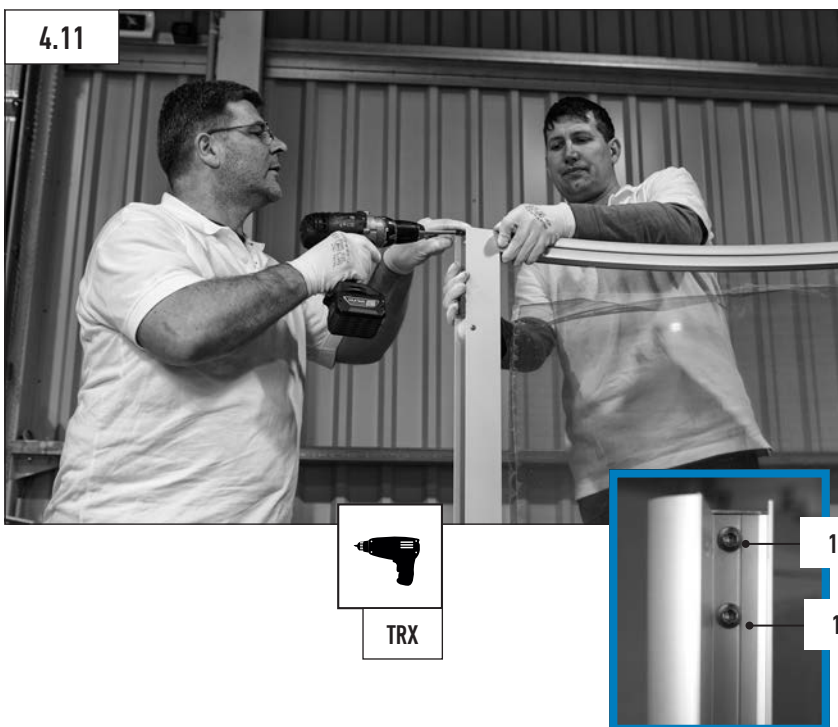

4 INTERMEDIATE SEGMENT ASSEMBLY

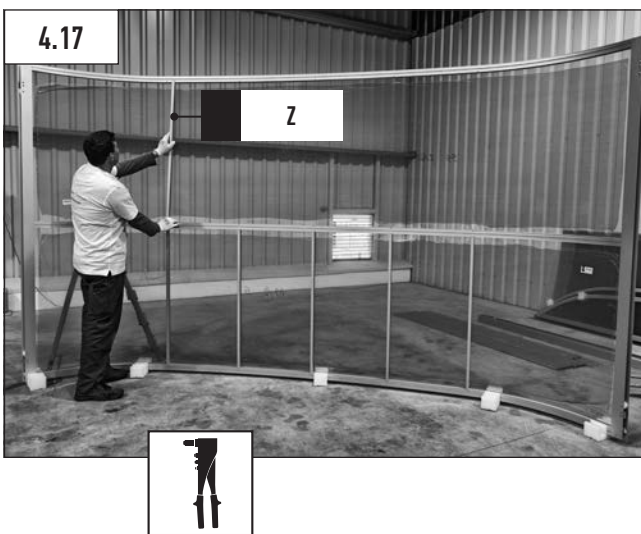
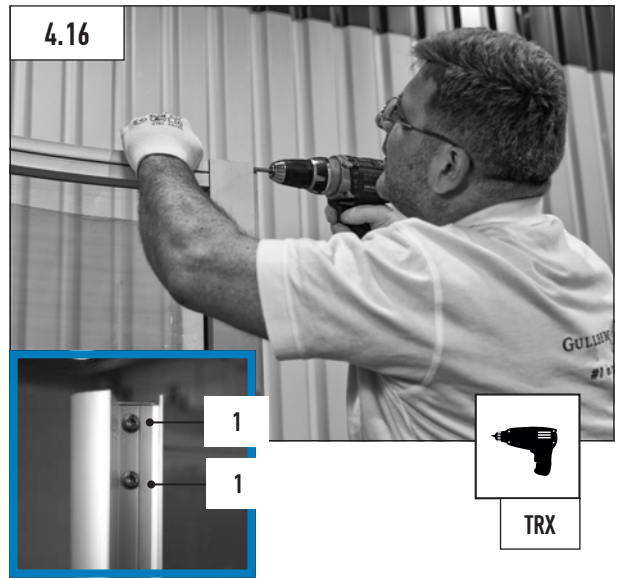
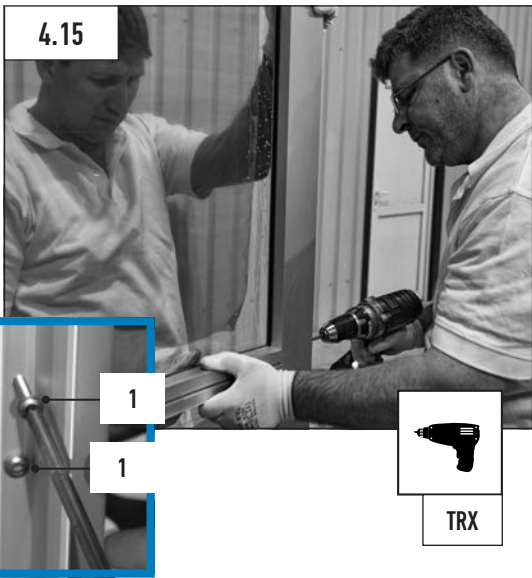
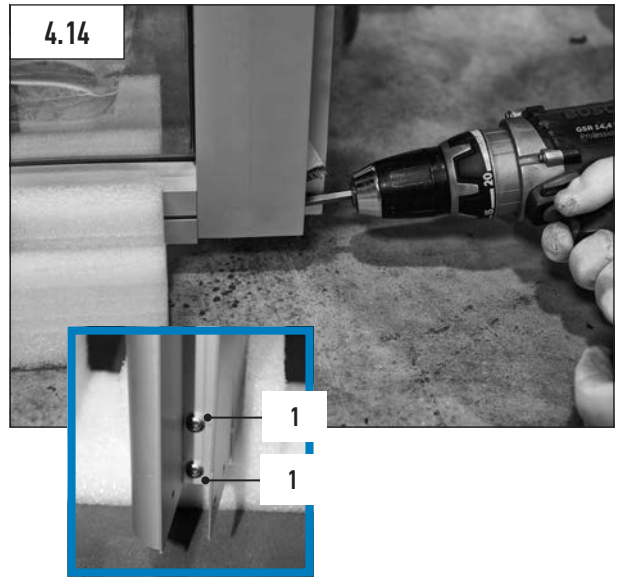

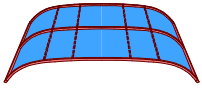

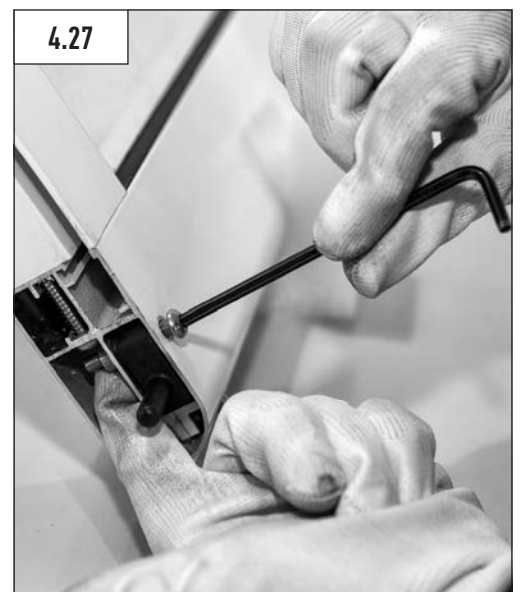
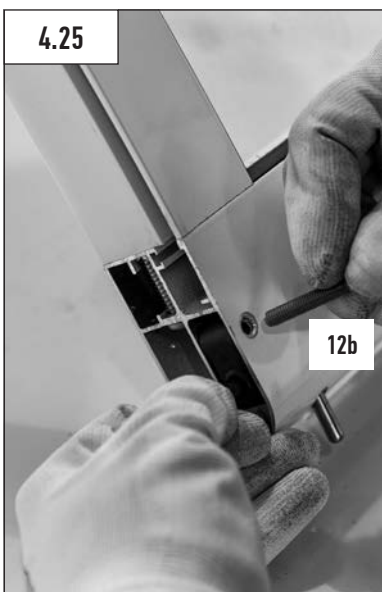
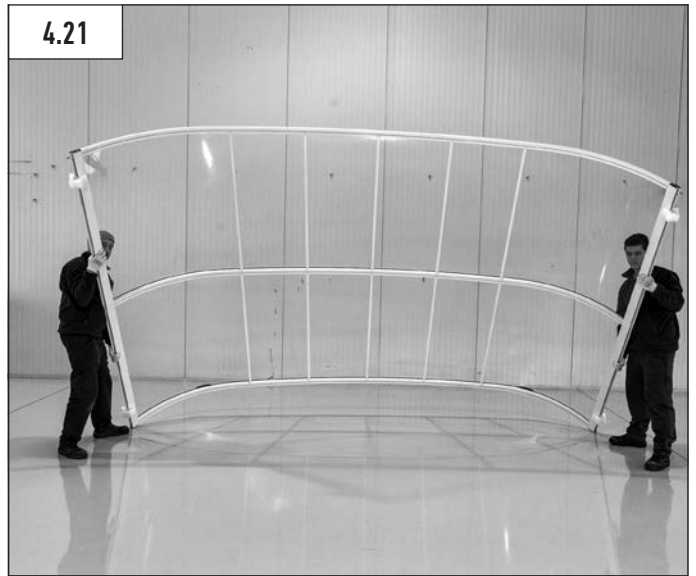

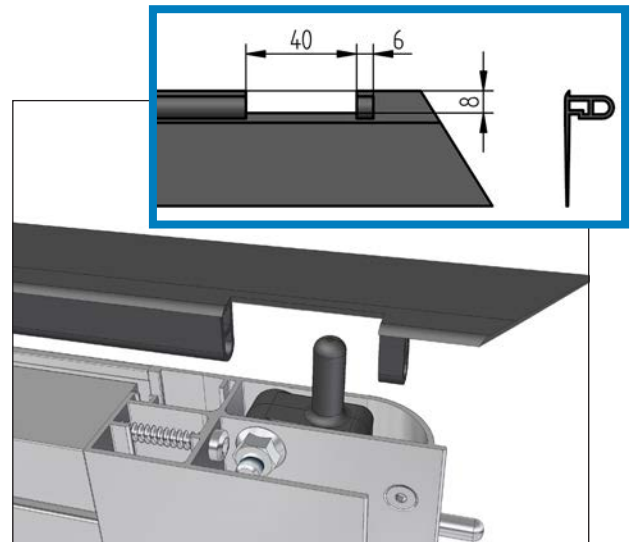
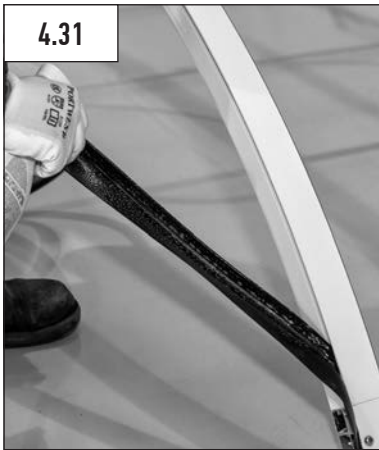

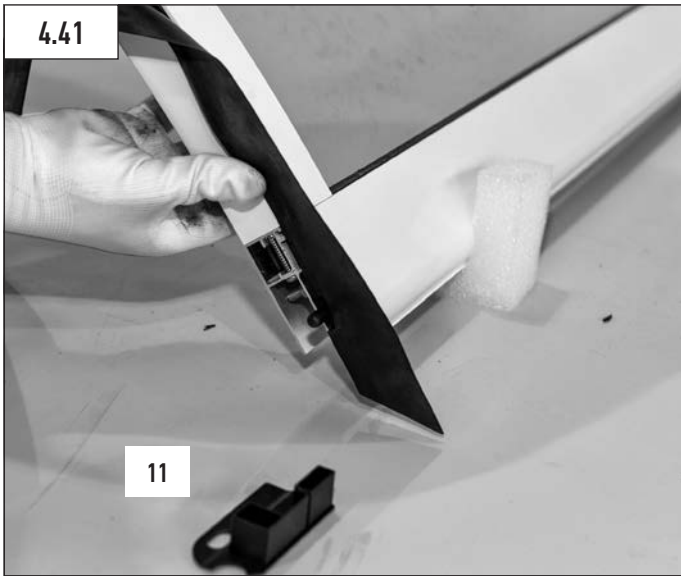

**Repeat steps 4.1 - 4.47
(see at page 30-36)**

5 SEGMENT RUBBER SEAL INSTALLATION

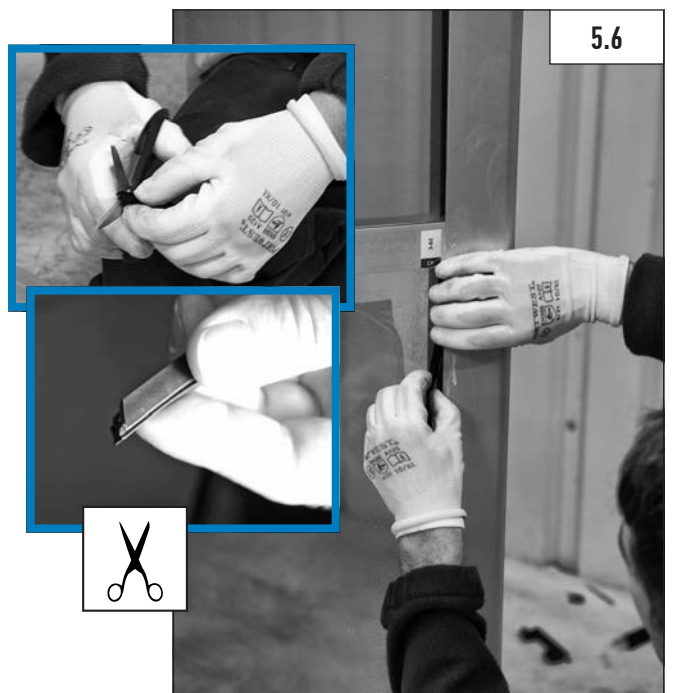
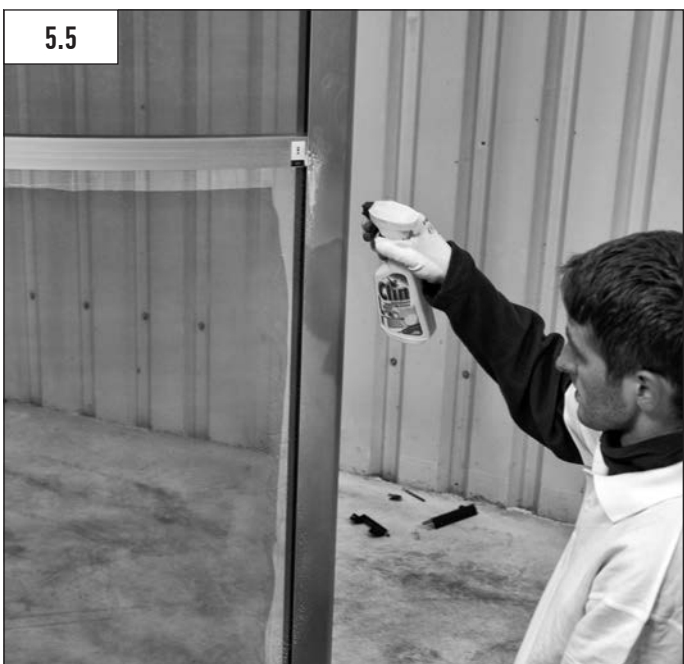
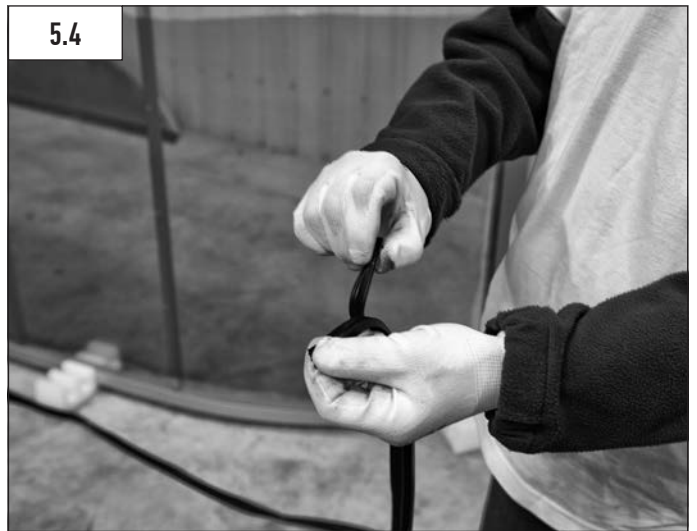

5 SEGMENT RUBBER SEAL INSTALLATION



5 SEGMENT RUBBER SEAL INSTALLATION

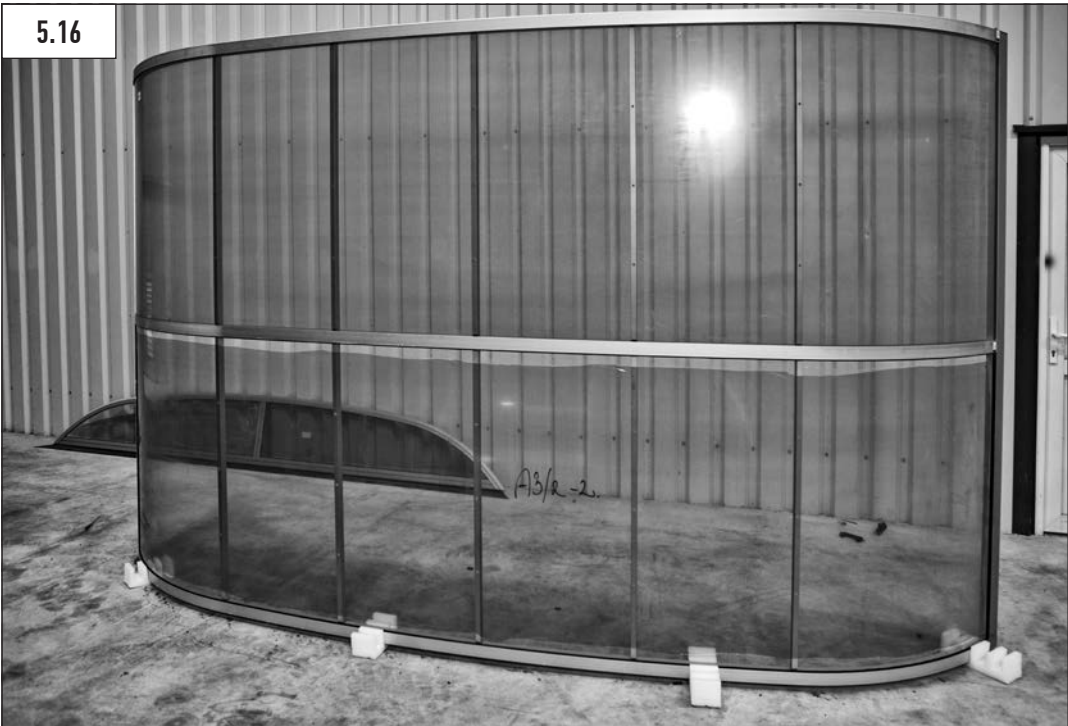

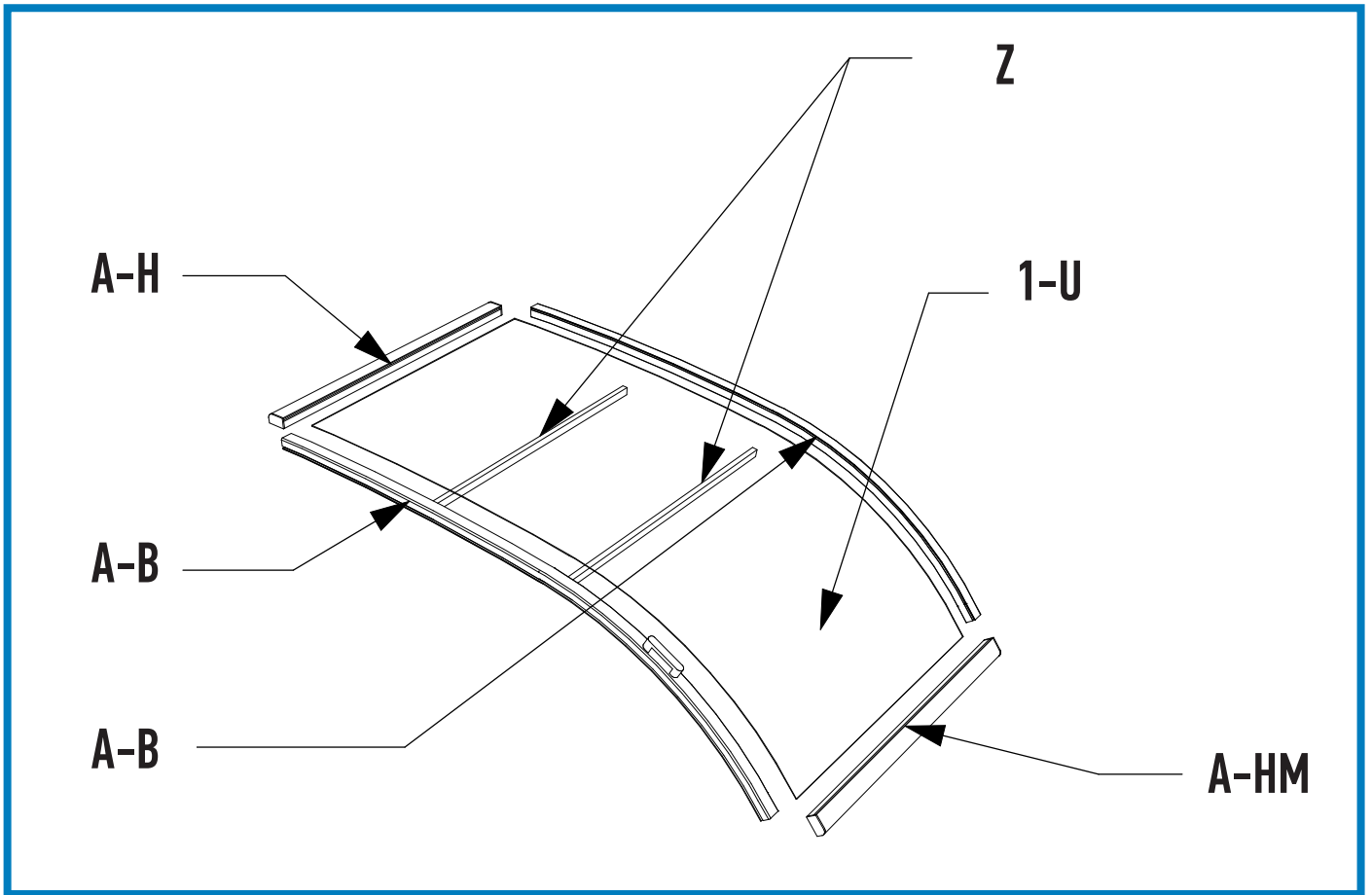

Item nr.	Item name	Pcs		Notes	
		A3/4 A3	A4L A4S		A4/5 A4
A-B	1. arch	1		1	
A-B	2. arch	1		1	
A-H	Receiver profile	1		1	
A-HM	Receiver profile marked	1		1	
1-U	PC Clear plate / PC Thermo plate	1		1	
Z	Linking hollow section	2		3	
1	Pen head torx screw	8		8	
15a	Sliding door lock	1		1	
17	Plastic plug	8		8	
21	Sliding door bottom rubber	1		-	
22	Outside rubber (double)*				

*With PC Clear plate

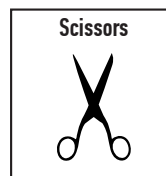
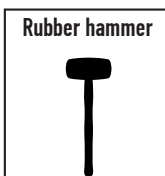
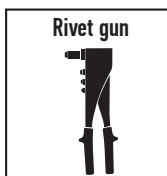
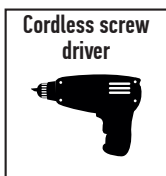

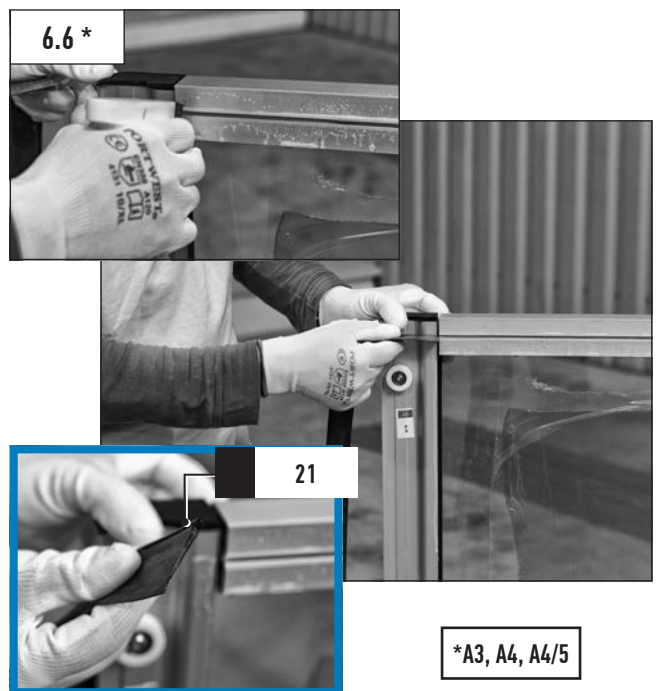
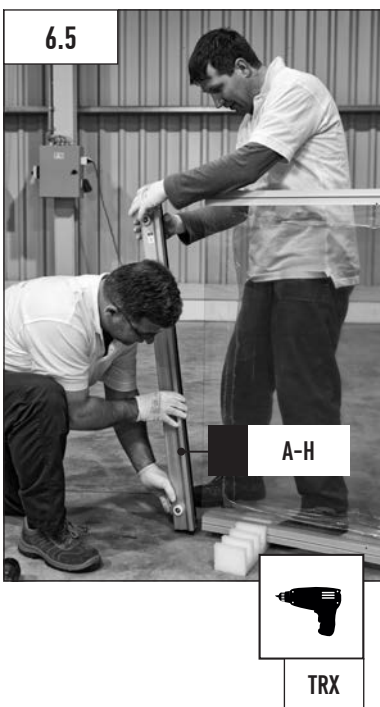
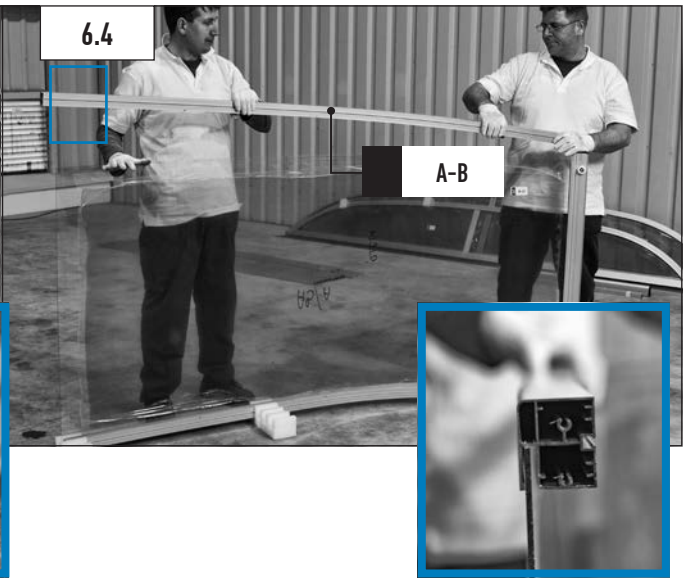
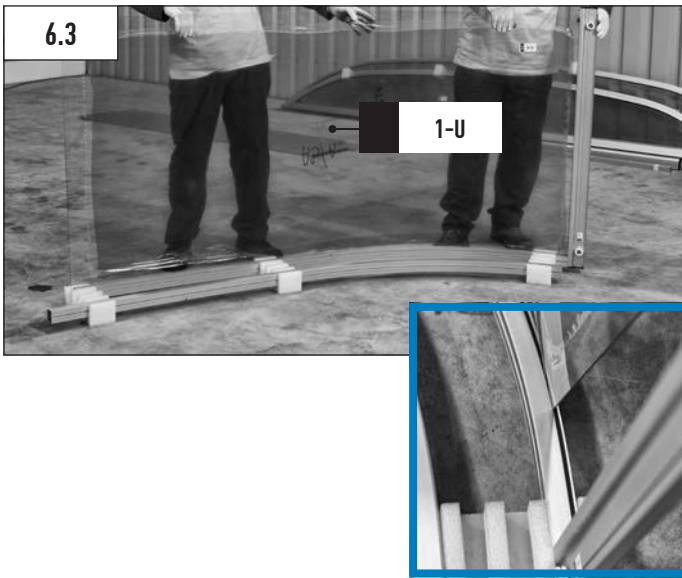
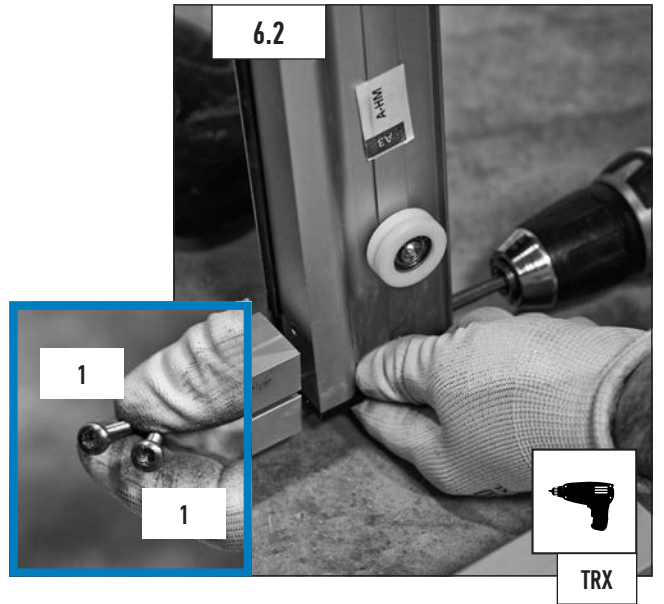
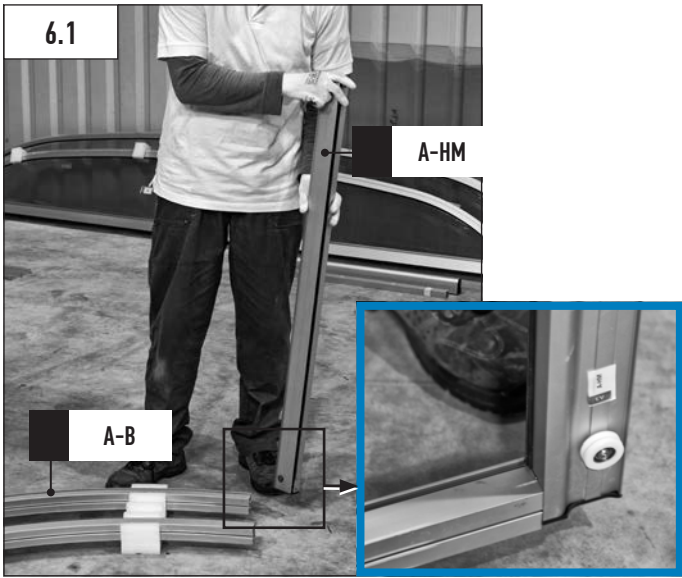

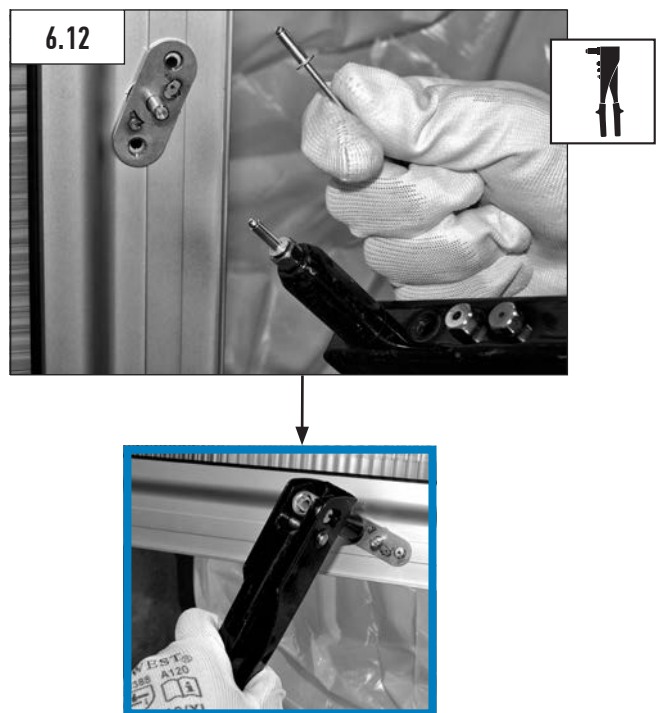
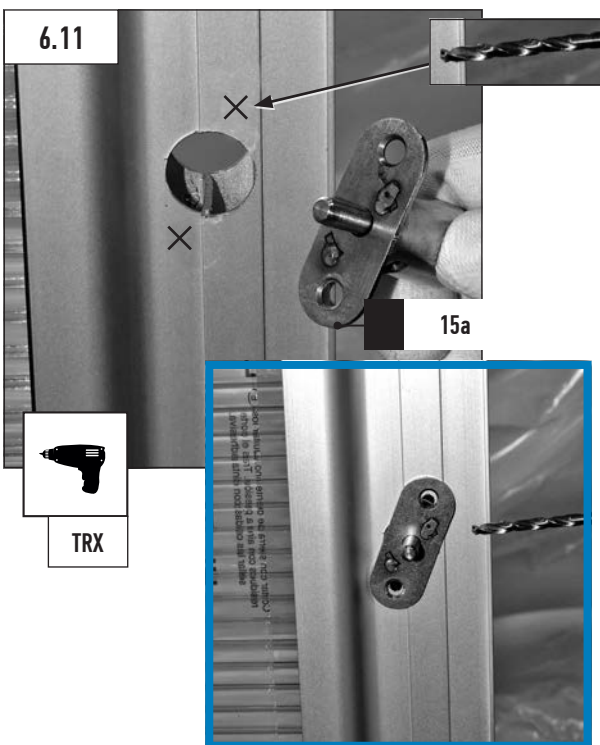
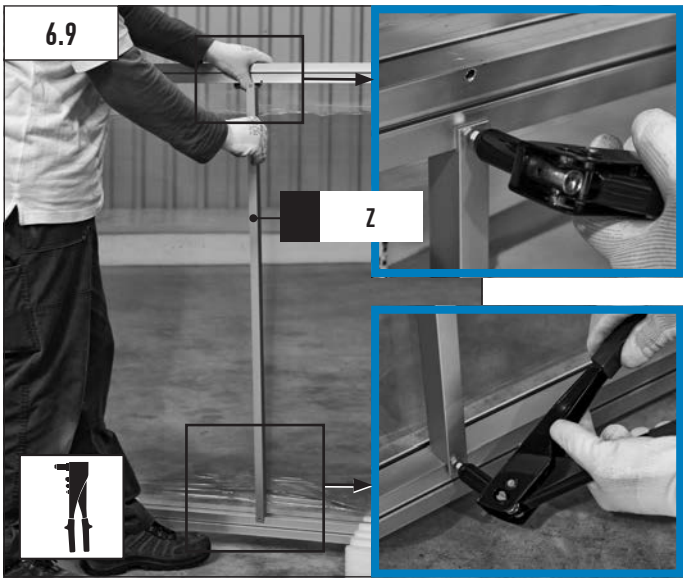
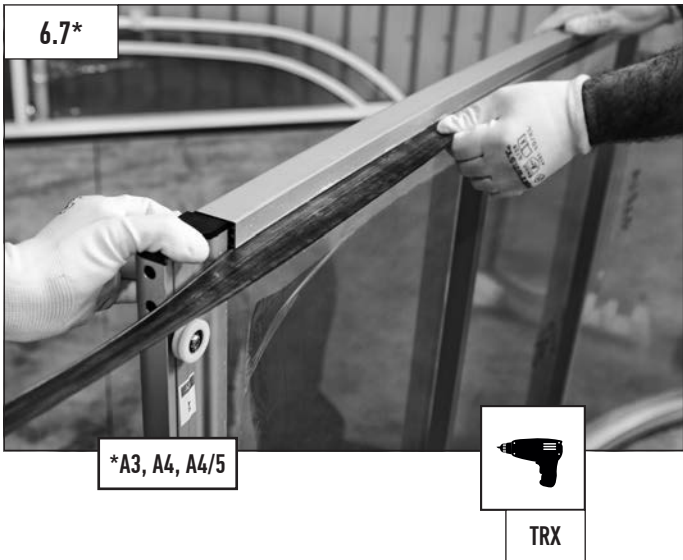

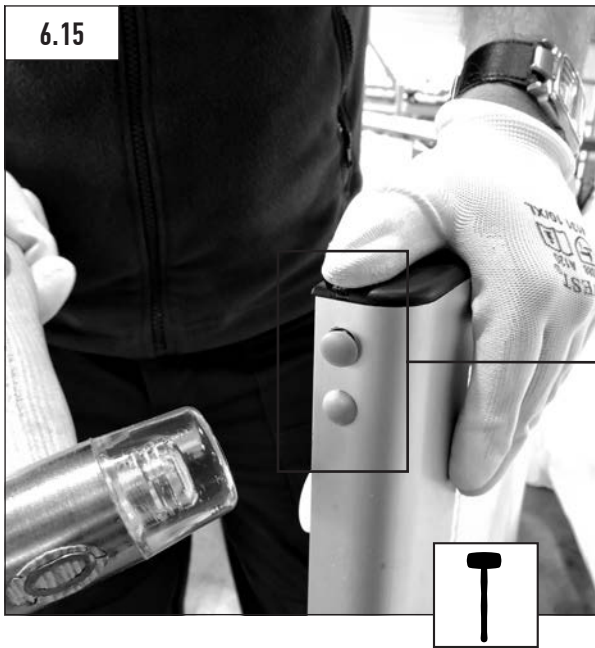

6 SLIDING DOOR RUBBER SEAL INSTALLATION (NEXT TO THE PC CLEAR PLATE)

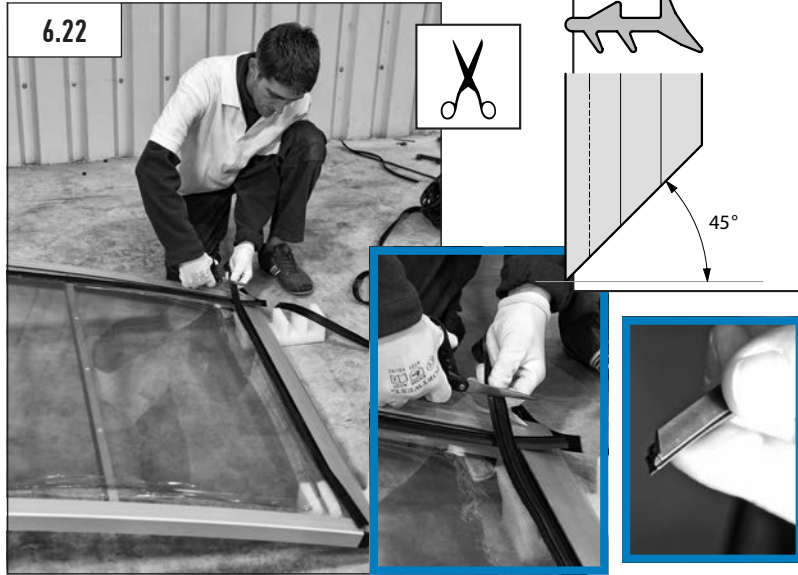
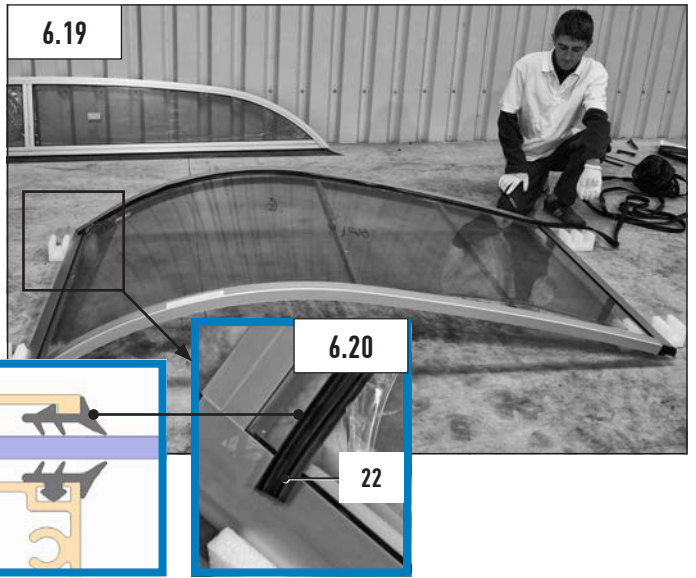
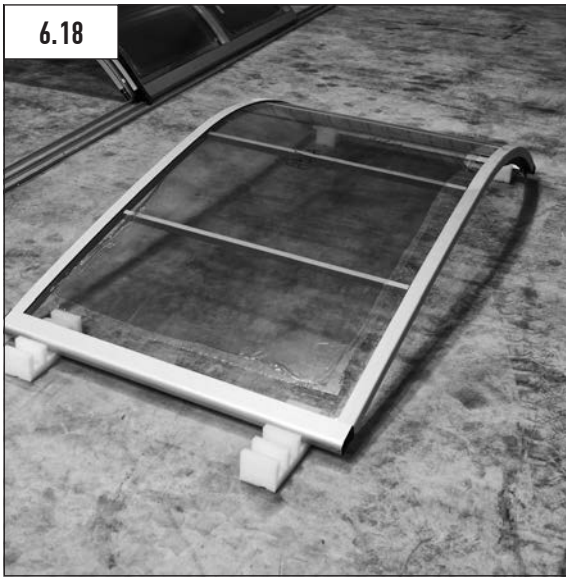

6 SLIDING DOOR RUBBER SEAL INSTALLATION (NEXT TO THE PC CLEAR PLATE)

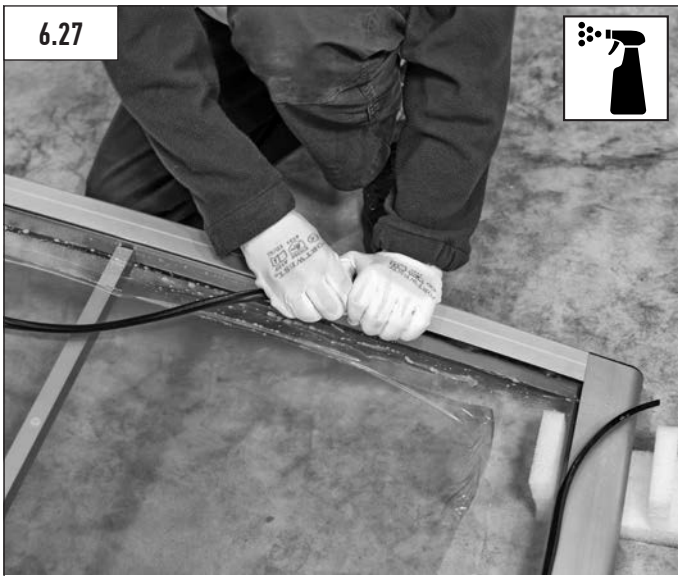
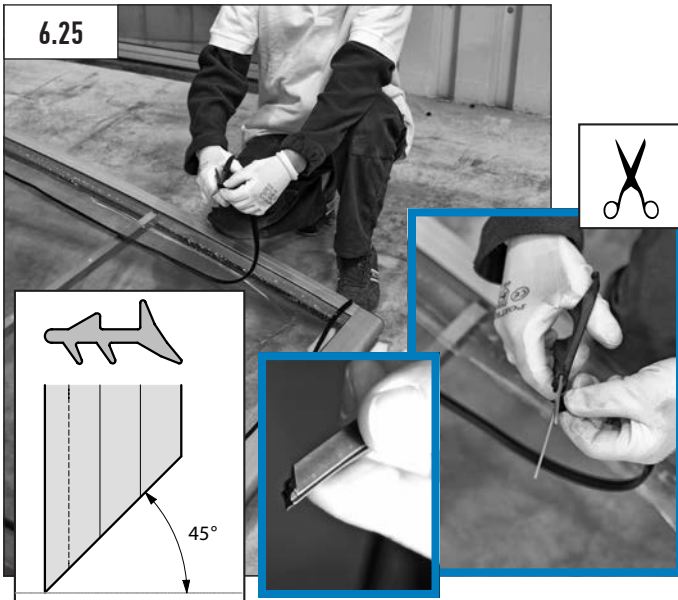

6 SLIDING DOOR RUBBER SEAL INSTALLATION (NEXT TO THE PC CLEAR PLATE)



7 MOUNTING SEGMENTS ONTO RAILS

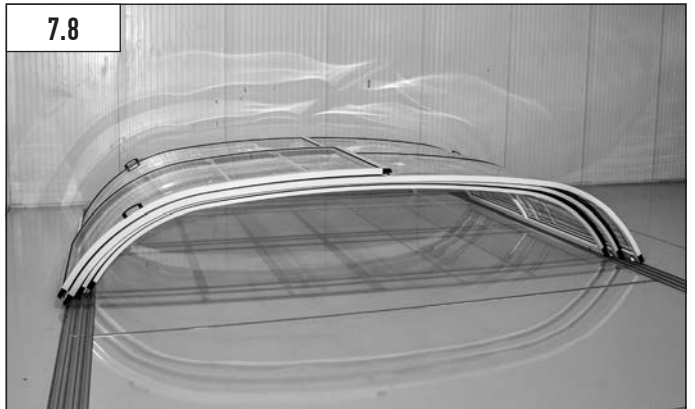
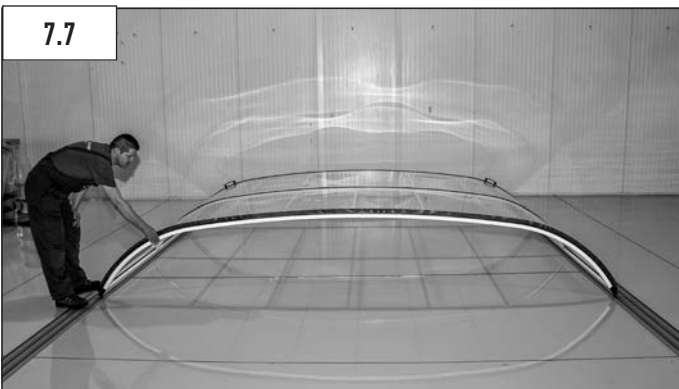
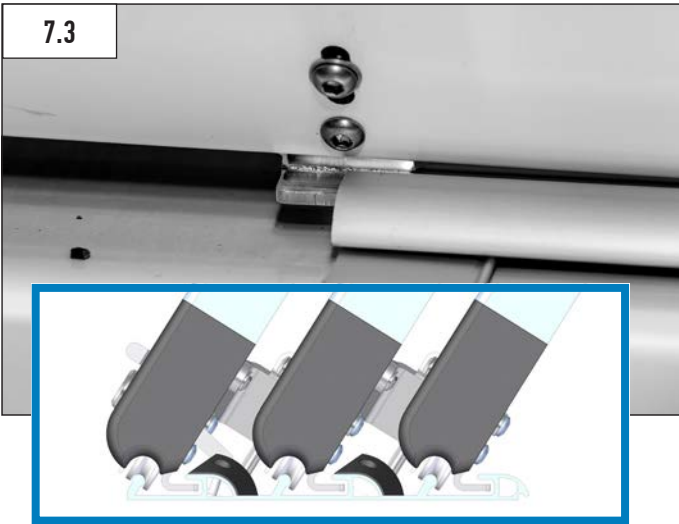
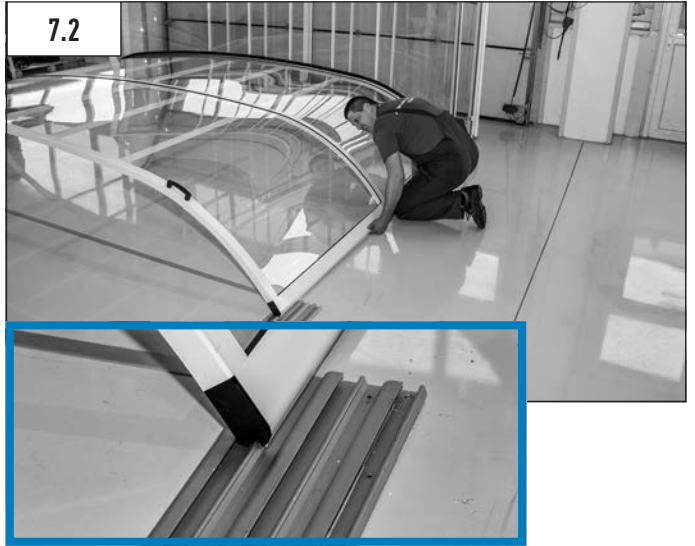



8 END WALL INSTALLATION - FIRST SEGMENT

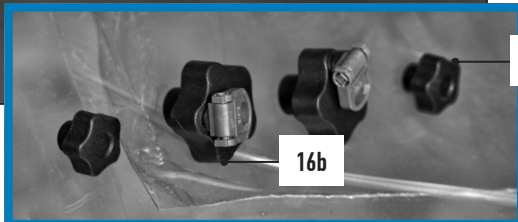
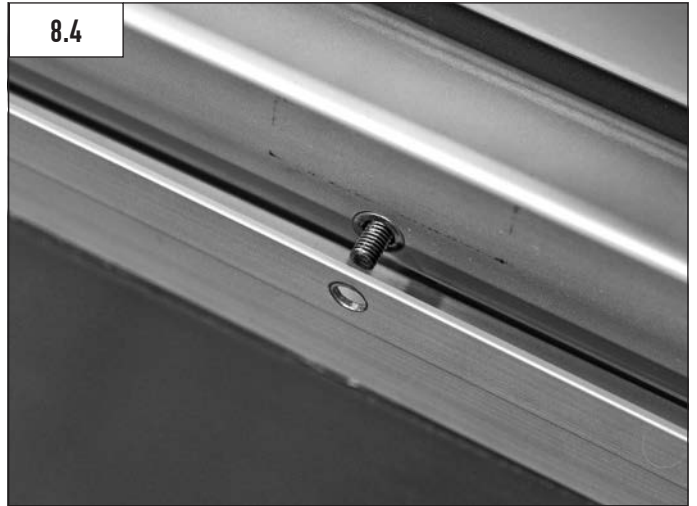

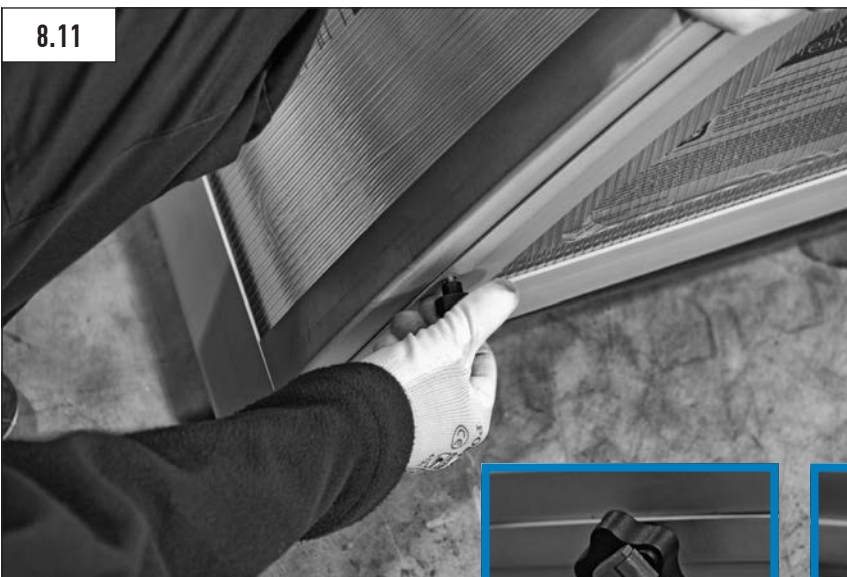
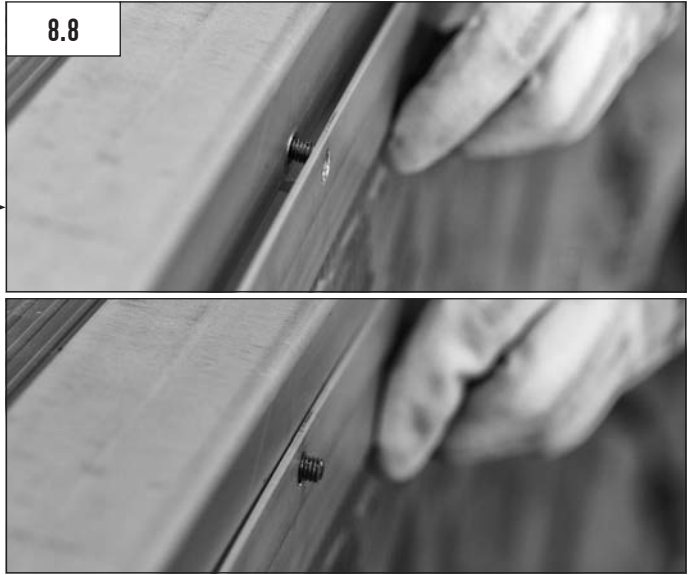

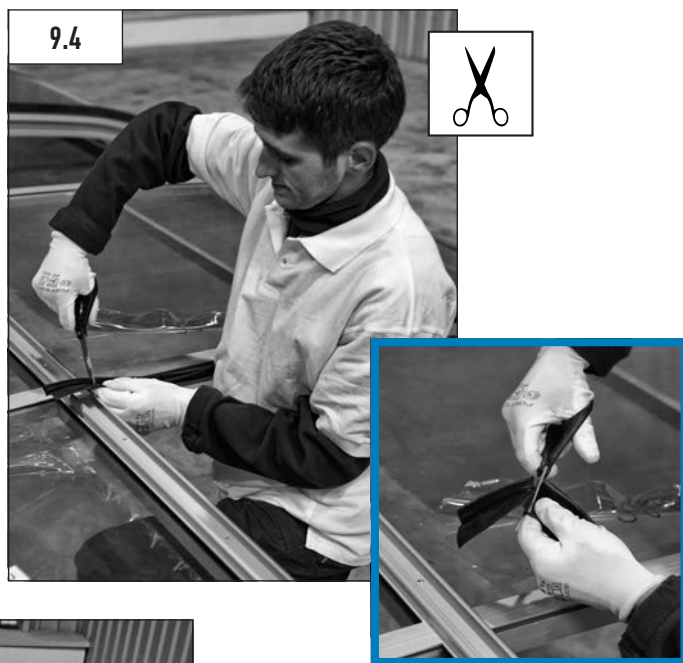
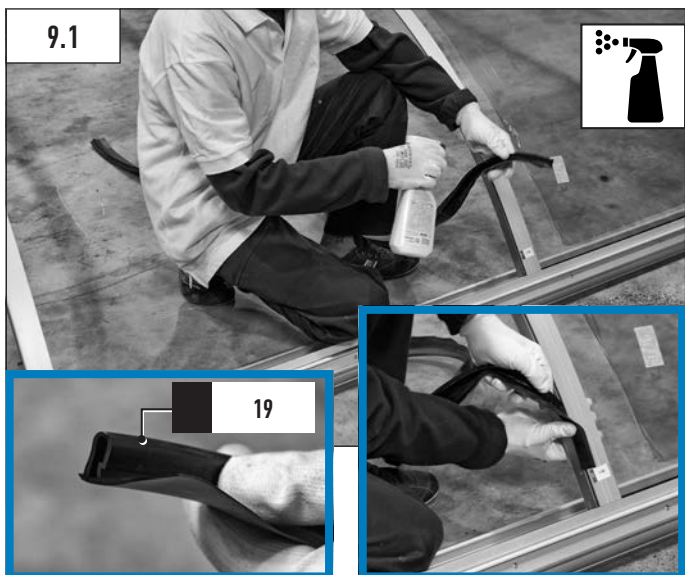

with A3 - A3/4 - A4S - A4L - A4 - A4/5 models

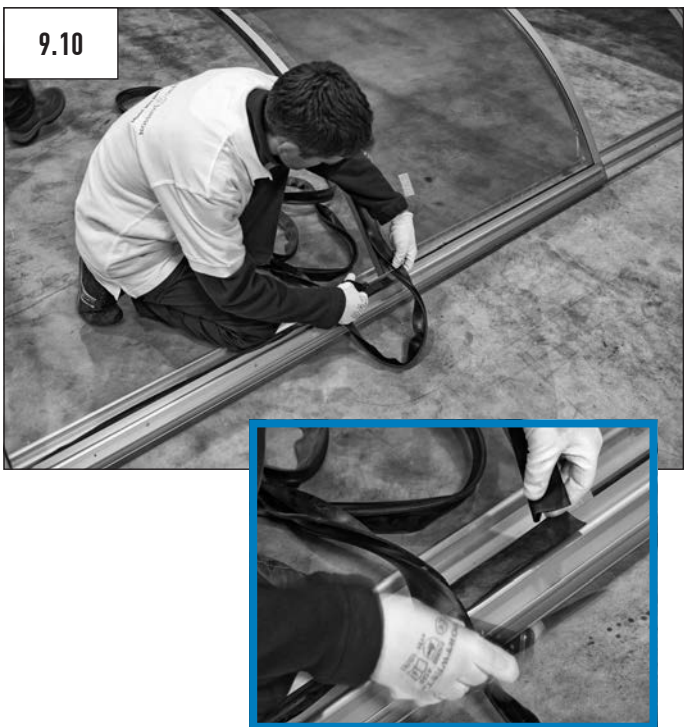
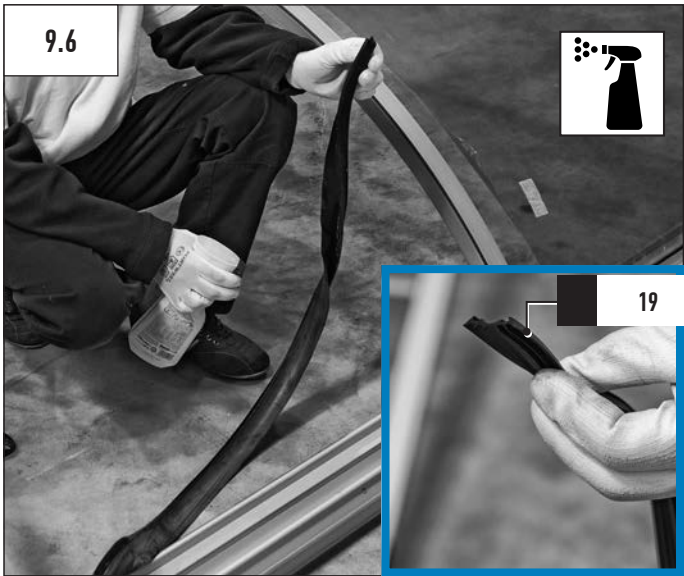



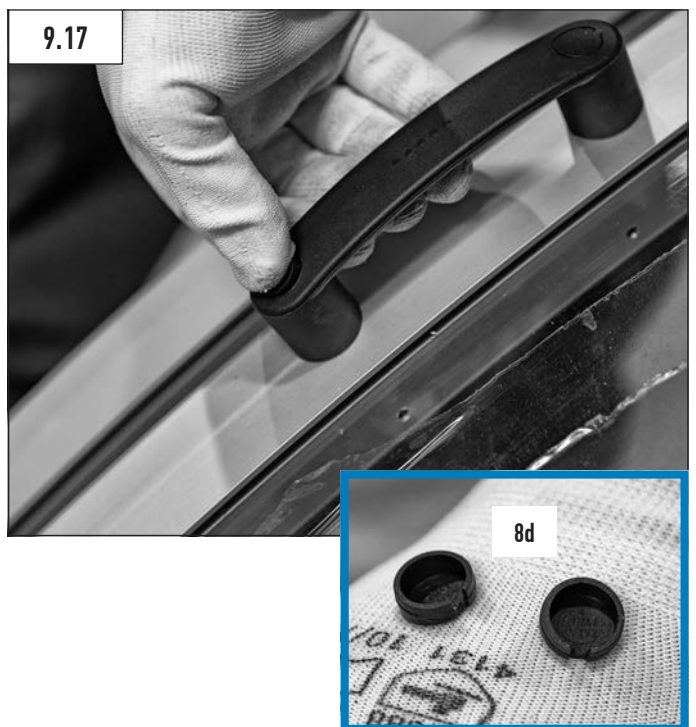
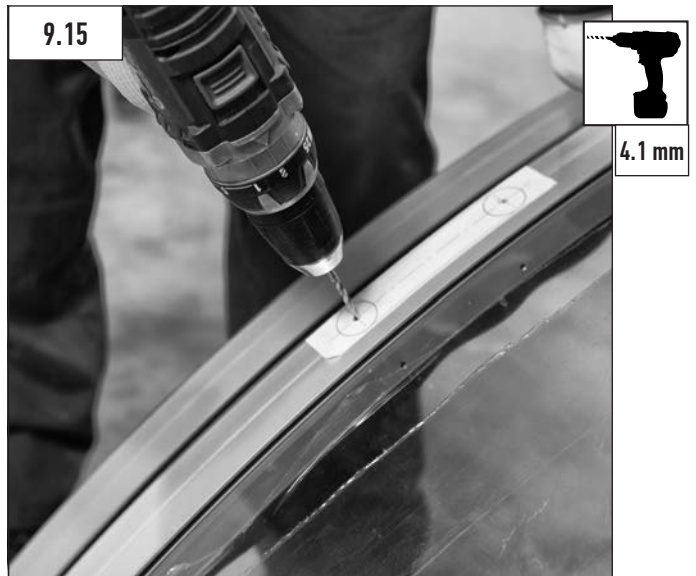
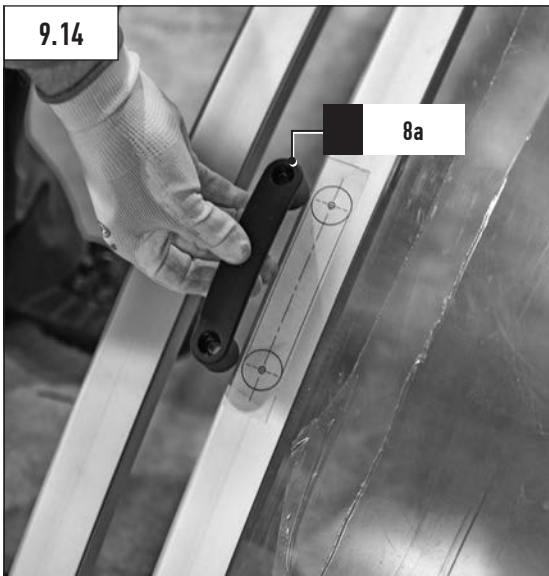
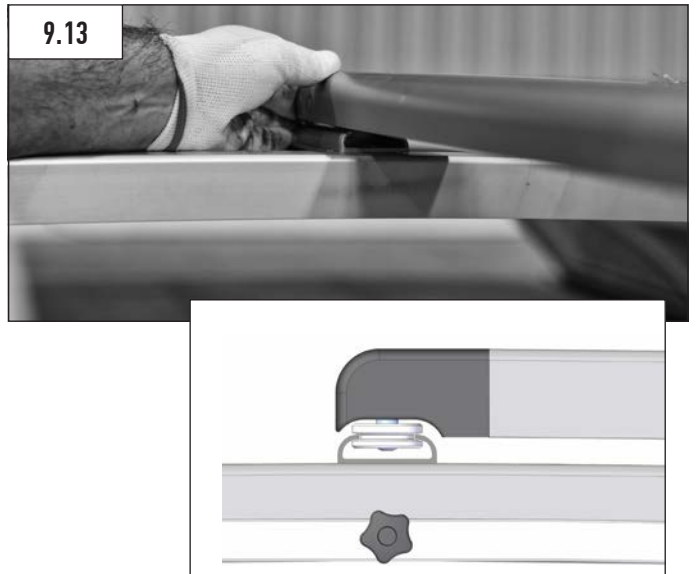

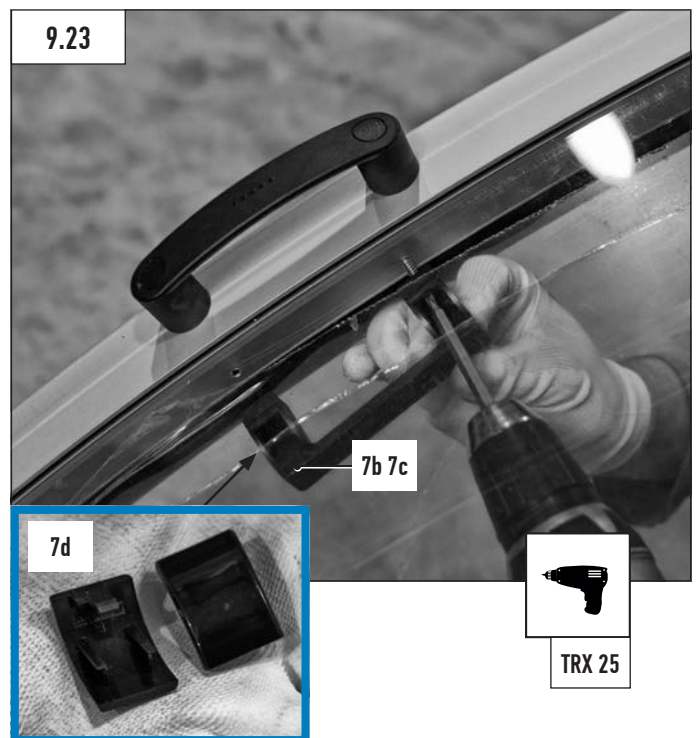
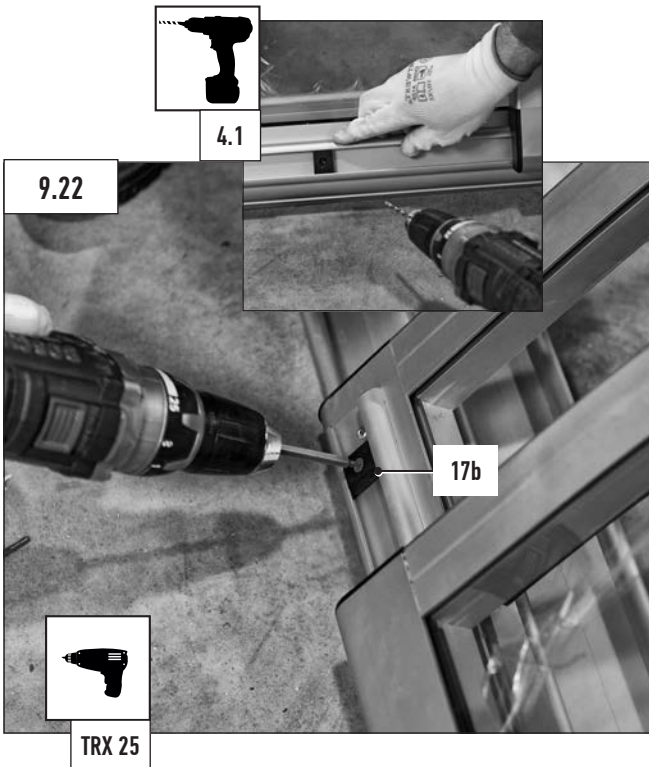
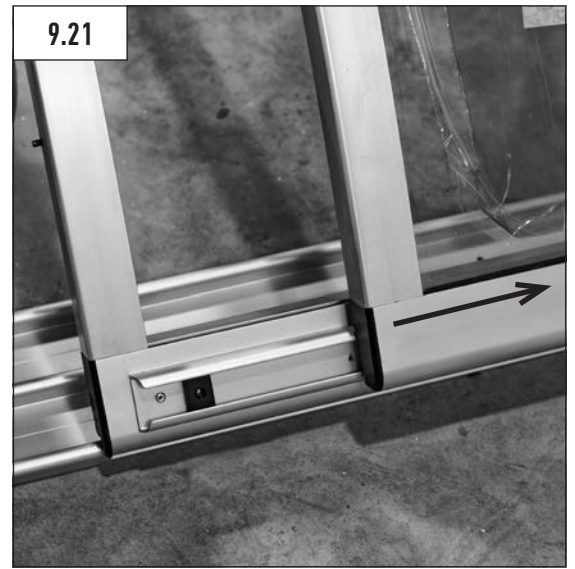
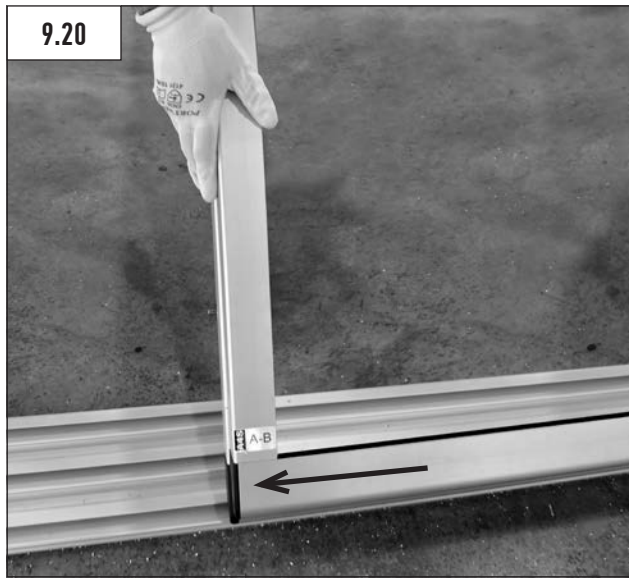
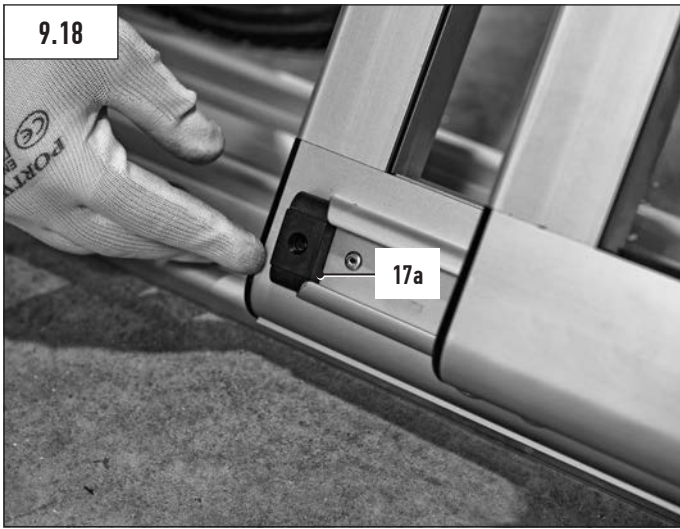

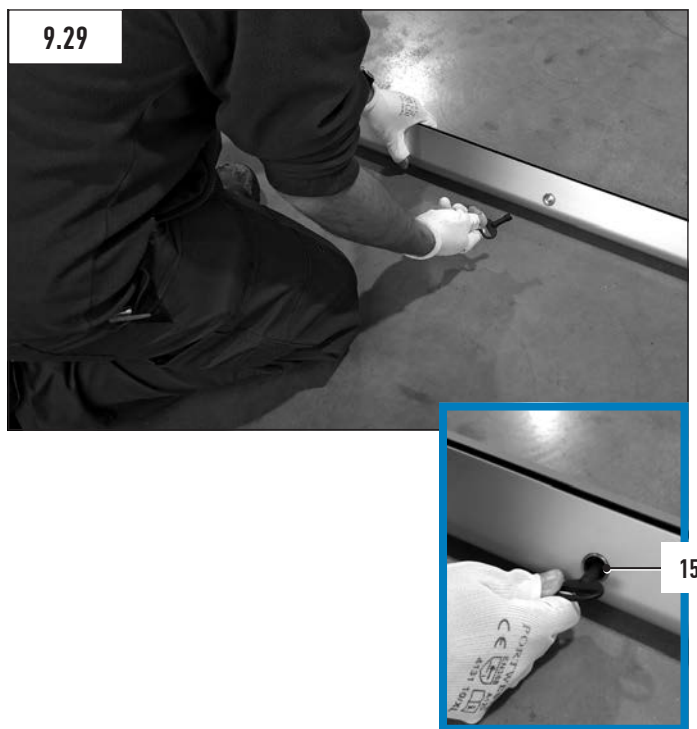
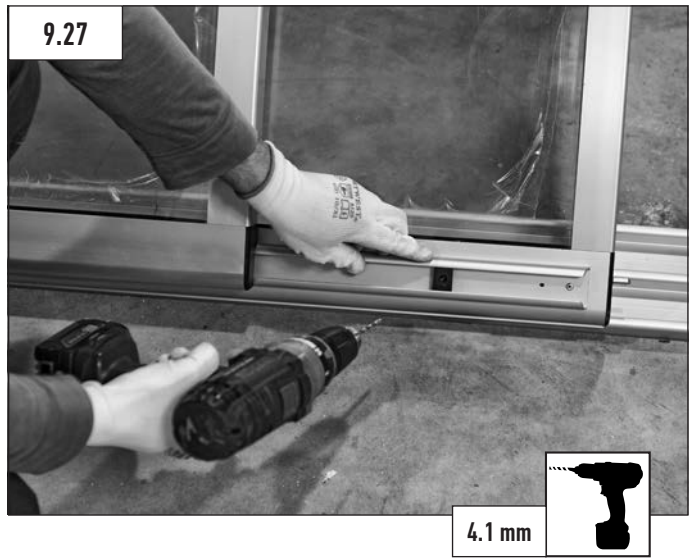

with A5 models

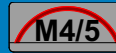



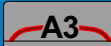
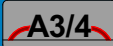

						
Item nr.	Item name	Pcs	Pcs	Pcs	Pcs	Notes
14c	Buffer	4	4	4	4	
14a	Rail joiner	6	8	10	10	
14b	End cap	12	16	30	30	1 left + 1 right
13	Latch sleeve	3	3	3	4	

								
								
Item nr.	Item name	Pcs	Pcs	Pcs	Pcs	Pcs	Pcs	Notes
14c	Buffer	4	4	4	4	4	4	
14a	Rail joiner	6	8	8	8	10	10	
14b	End cap	12	16	16	16	30	30	1 left + 1 right
13	Latch sleeve	0	0	2	2	2	4	

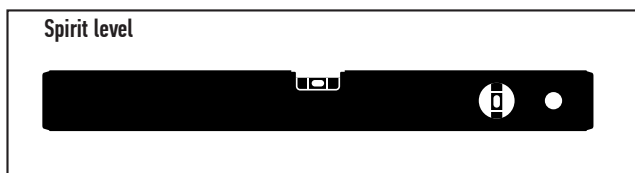
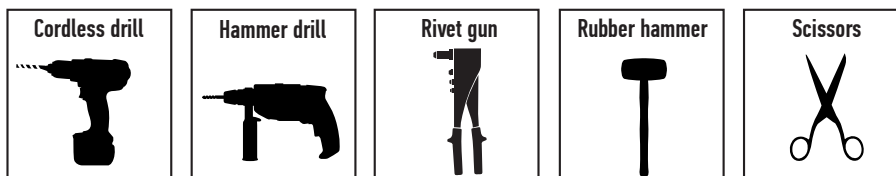

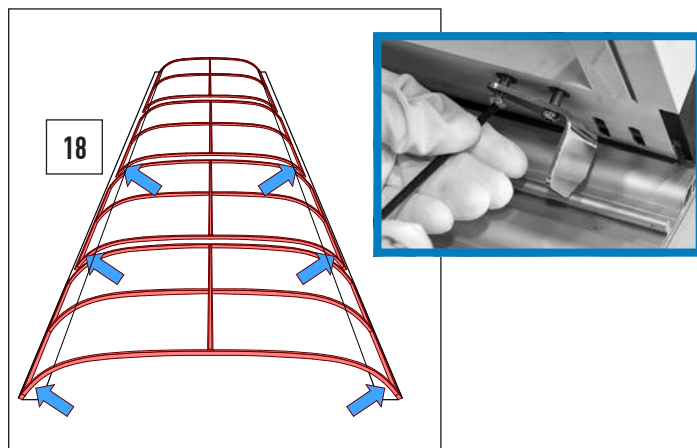
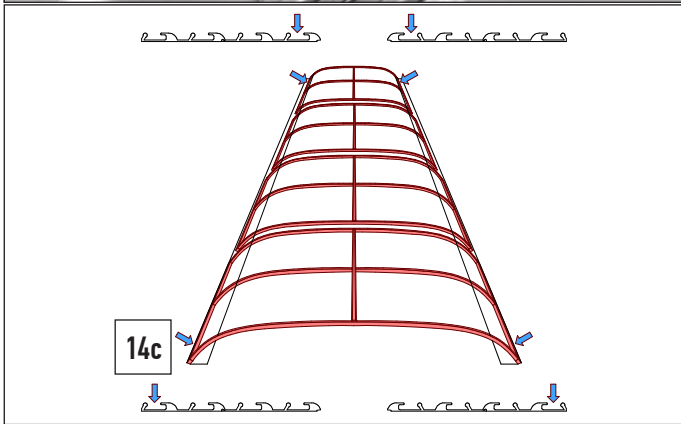
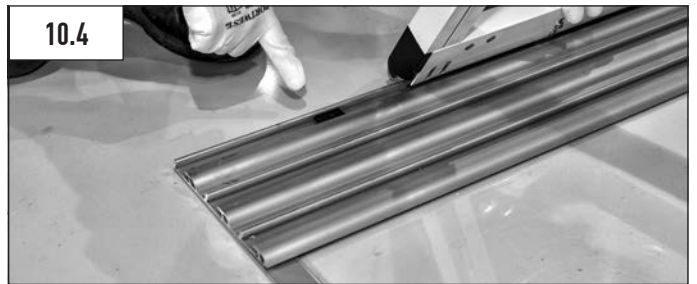
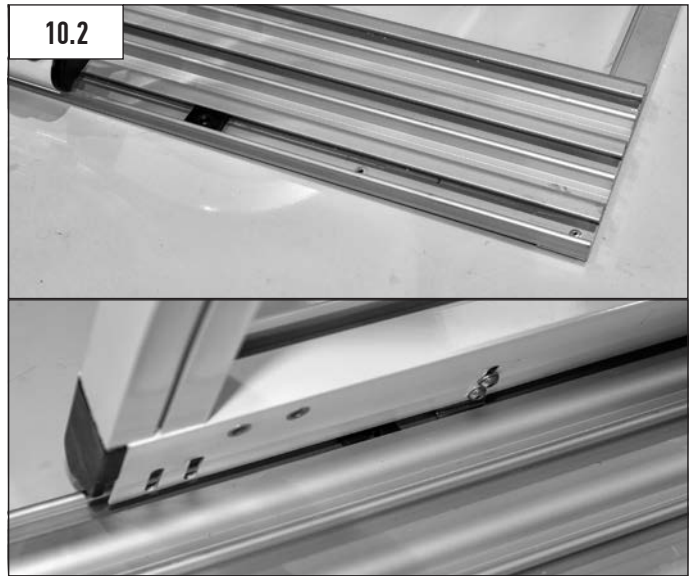
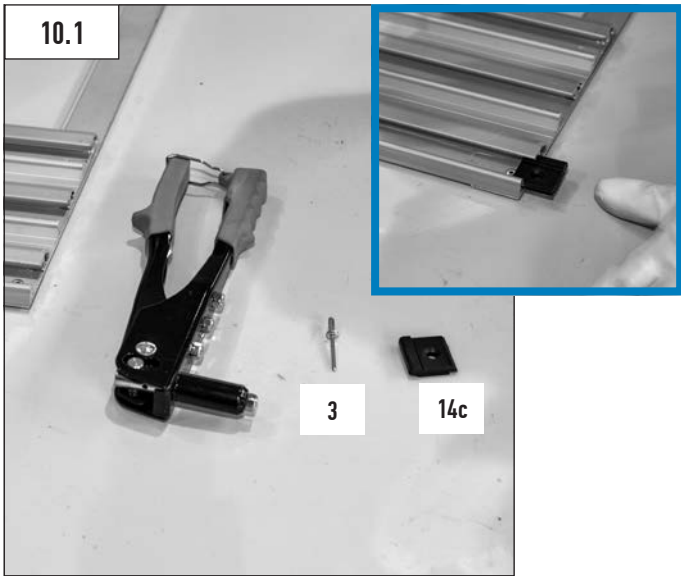

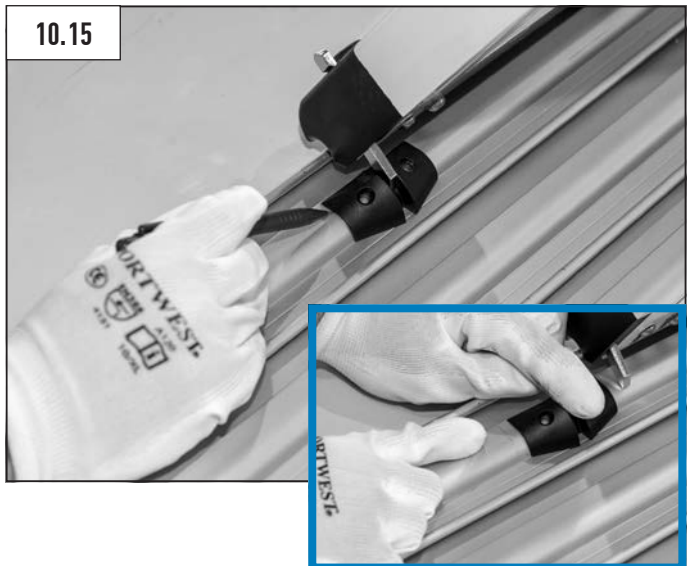
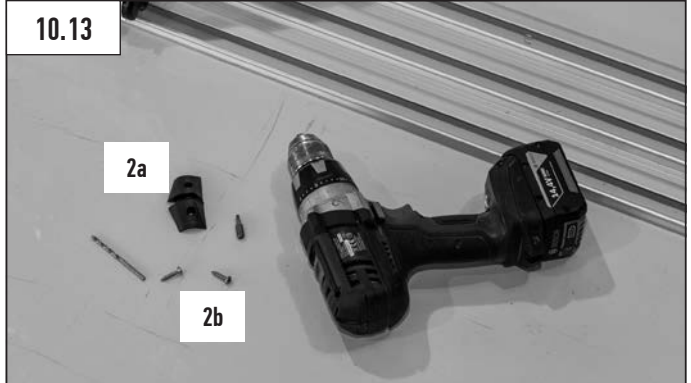
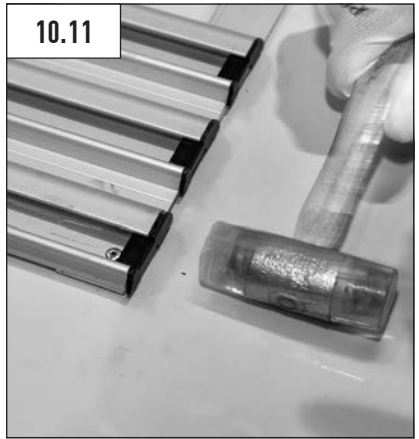
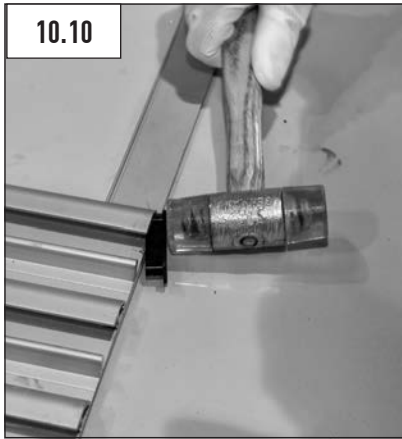
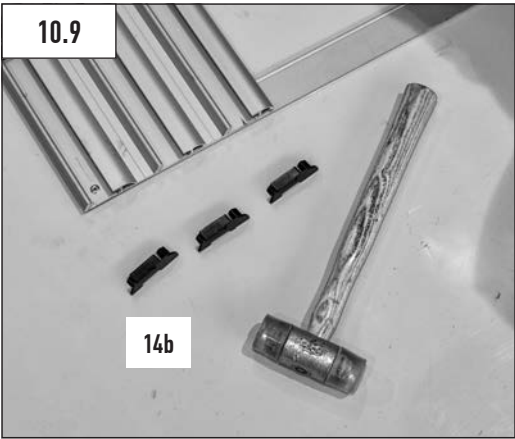
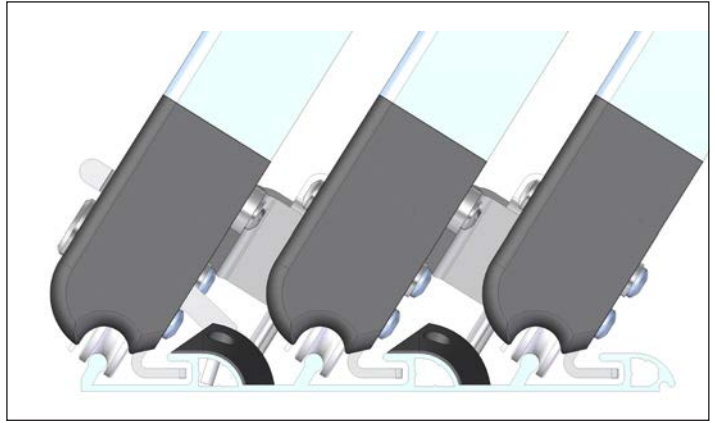

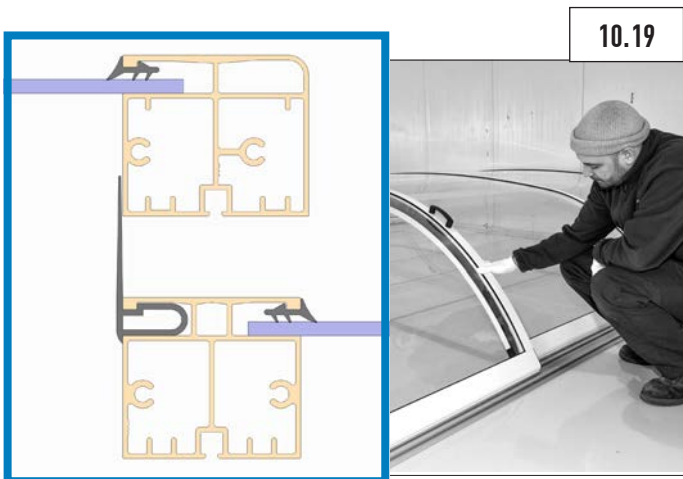
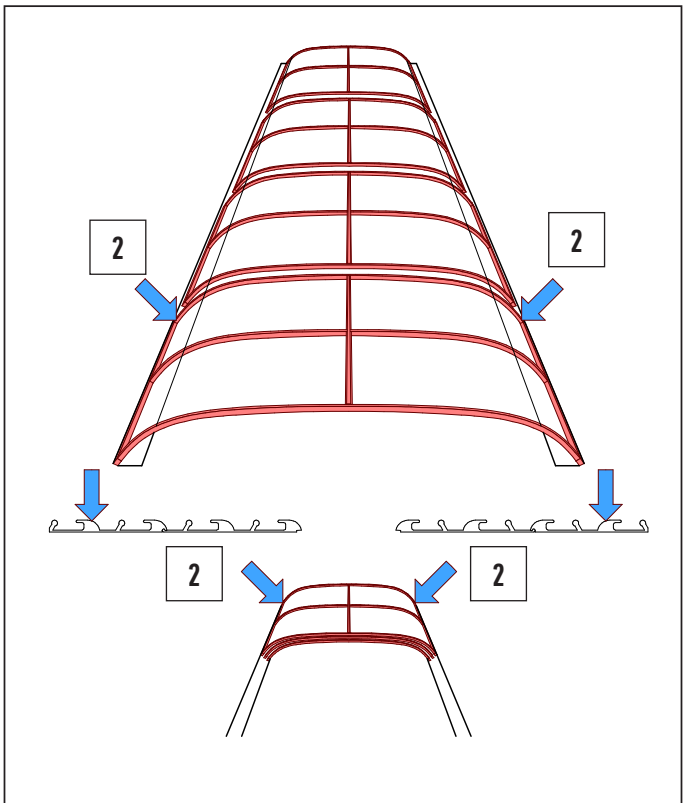
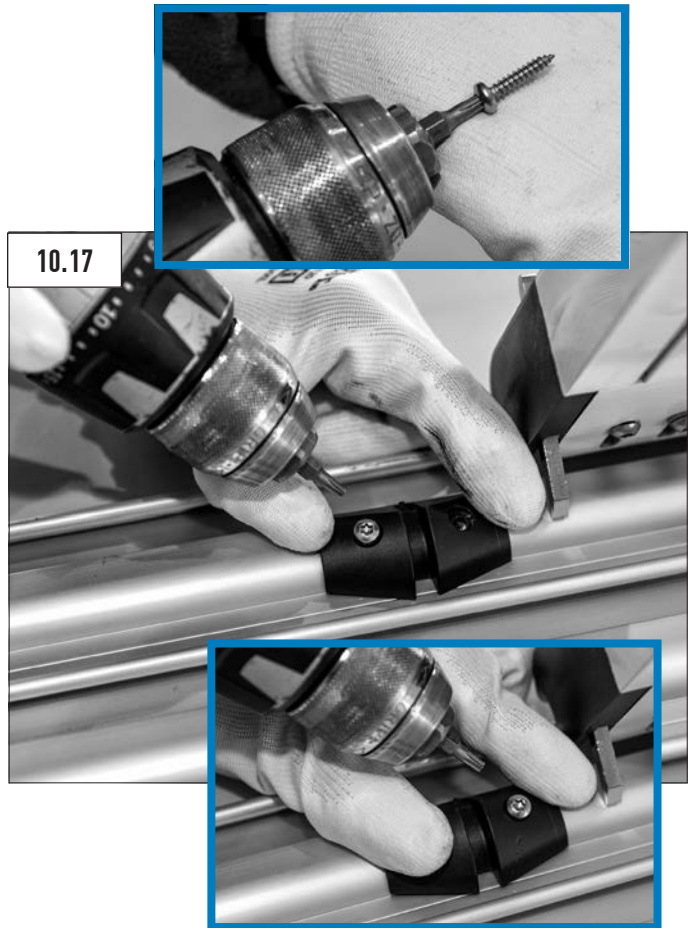

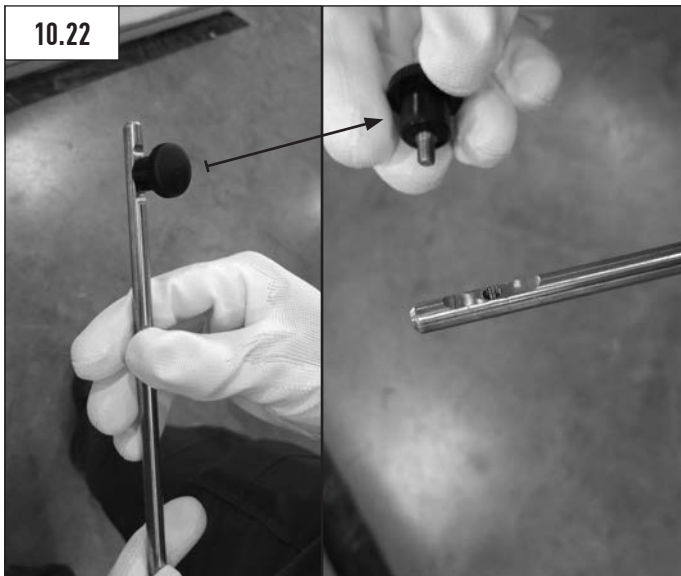
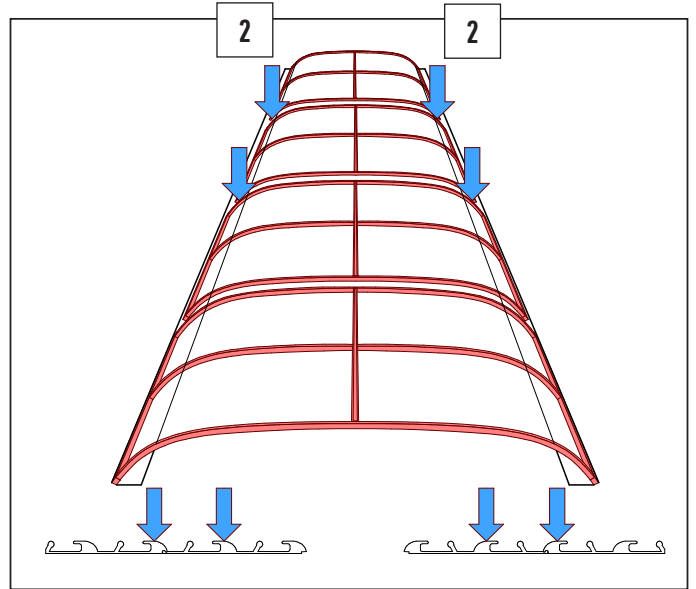

* NOT FOR A3, A3/4.

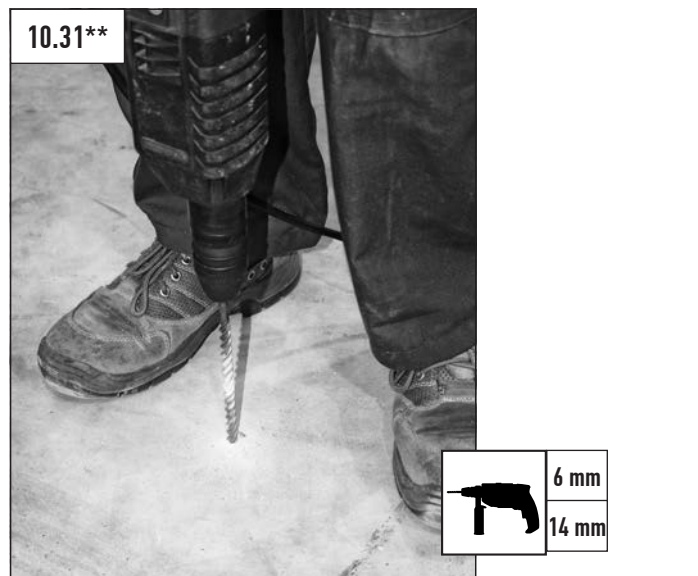
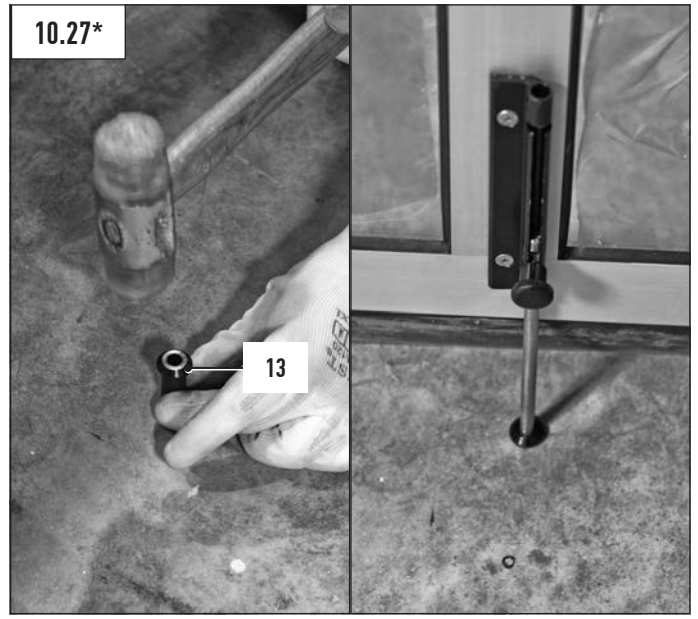
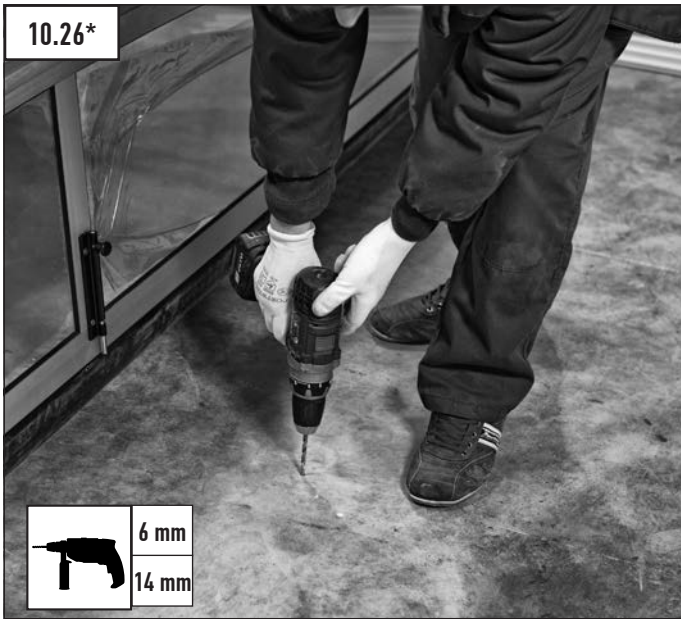

* FLAT MODELS (A) = FRONT AND BACK WALL
STANDARD MODELS (M) = ONLY BACK WALL

**STANDARD MODELS (M) = ONLY FRONT WALL



**STANDARD MODELS (M) = ONLY FRONT WALL



