



# Manual

PLP-REM



20-08-21

HOUSE OF  
**DURATECH**  
— innovative pool products —

# LINK Driver



## Table of contents

Technical specifications	
General Specifications .....	<b>Page 4</b>
Logic board .....	<b>Page 5</b>
Installation Instructions	
Single PLP-REM unit .....	<b>Page 6</b>
Multiple PLP-REM installation.....	<b>Page 7</b>
Operation modes .....	<b>Page 8</b>
DIP switch functionalities .....	<b>Page 9</b>
Transmitter functions	
Operation mode: PLC .....	<b>Page 10</b>
Operatio mode: ON/OFF.....	<b>Page 10</b>
Replacing transmitter keypad.....	<b>Page 11</b>
Pairing the handheld transmitter .....	<b>Page 11</b>
DMX 512 communication	
Single PLP-REM unit .....	<b>Page 12</b>
Multiple PLP-REM installation.....	<b>Page 13</b>
RS-485 communication	
Single PLP-REM unit .....	<b>Page 14</b>
Multiple PLP-REM installation.....	<b>Page 14</b>
RS-485 command set.....	<b>Page 15</b>
RESET procedure .....	<b>Page 16</b>
Transmitter battery.....	<b>Page 16</b>
Troubleshooting.....	<b>Page 17</b>
Pool light wiring instructions .....	<b>Page 18</b>
Wiring remark .....	<b>Page 19</b>

# Technical specifications

## General specifications

Input Voltage:	12VAC 50Hz $\pm$ 10%
Max rating "12VAC TO LAMPS" contact	58A / 12VAC
Max rating relay contact A &B	16A / 250 VAC
Max switching power A & B	4000VA
RF band	868 MHz
Ambient Air Temperature:	0°C to +40°C
Humidity	10% to 90% RH non condensing
Ingress protection rate:	IP54
IEC Protection Class:	Class II 

# Logic board

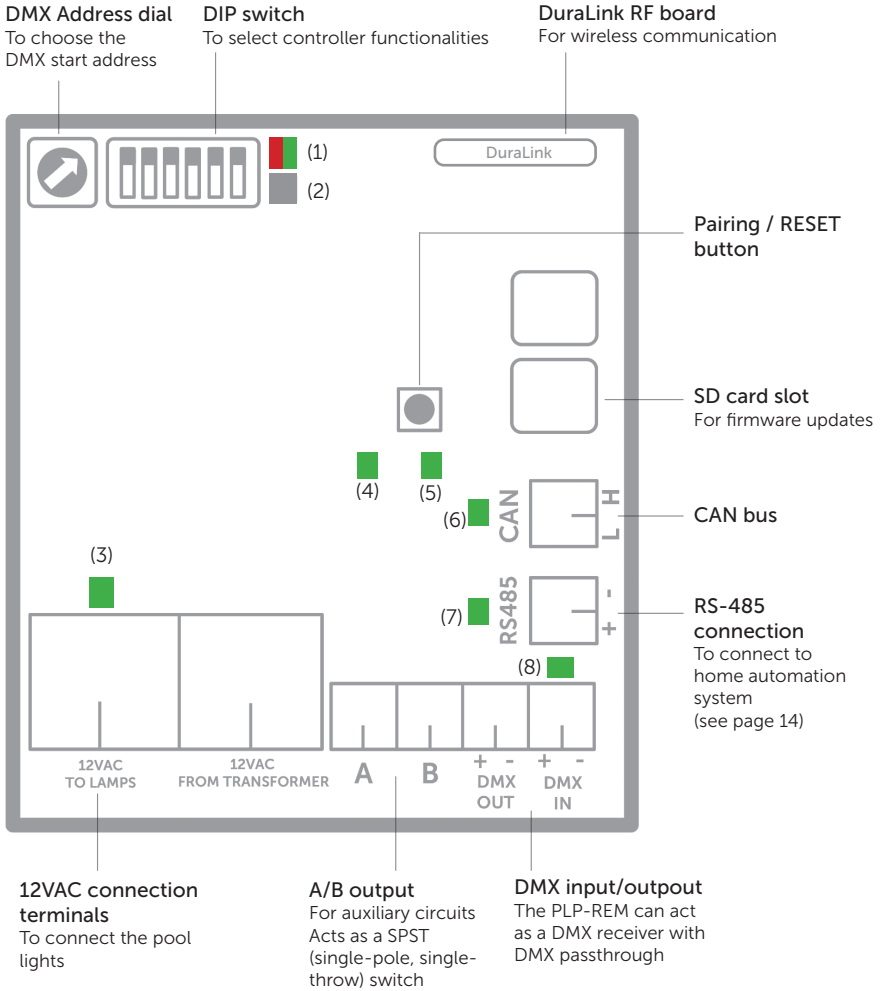

## Status LED's:

- (1) General status  
Green = OK  
Red = error overvoltage or overcurrent
- (2) Pairing / RESET status
- (3) 12VAC to Pool lamps (Green = ON)
- (4) Switch A (Green = ON)
- (5) Switch B status (Green = ON)
- (6) CAN status
- (7) RS-485 signal
- (8) DMX signal

# Installation Instructions

## Single PLP-REM unit

- Connect a 12VAC magnetic transformer to the "12VAC FROM TRANSFORMER" terminal of the PLP-REM.  
Connect the pool lights to the "12VAC TO LAMPS" terminal in the PLP-REM.
- Install the filter  (included in box) to the primary circuit (230VAC side) of the transformer
- The "12VAC TO LAMPS" relay contact has a max rating of 58A. Make sure the total power load does not exceed this ( $58A \times 12VAC = 696VA$ )

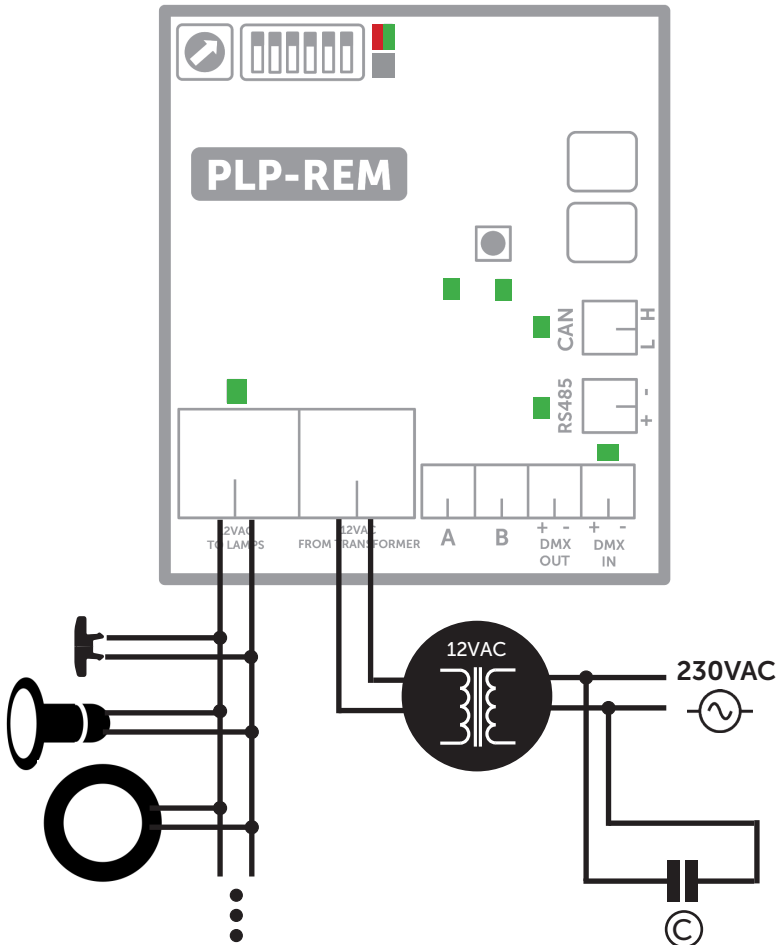

## Multiple PLP-REM installation

For extended installations (total lamp power > 700VA), multiple PLP-REM's can be linked together. This way, a perfect synchronisation of all pool lights is still guaranteed.

The PLP-REM's need to communicate with each other, to ensure all the lamps are in perfect sync.

Connect the PLP-REM's with each other using the CAN bus:

Connect the CAN terminals of the first PLP-REM with the CAN terminal of the second PLP-REM\*.

If more than 2 PLP-REM's are necessary, simply daisy chain each CAN terminal with the one from the next PLP-REM (see below). Respect the polarity of the terminals! (CAN L & H)

Next, set the DIP switches on the PLP-REM's to the correct MASTER/SLAVE setting. The first PLP-REM will be the MASTER. All the others will be SLAVE'S. Refer to page 9 for Master/Slave DIP switch info.



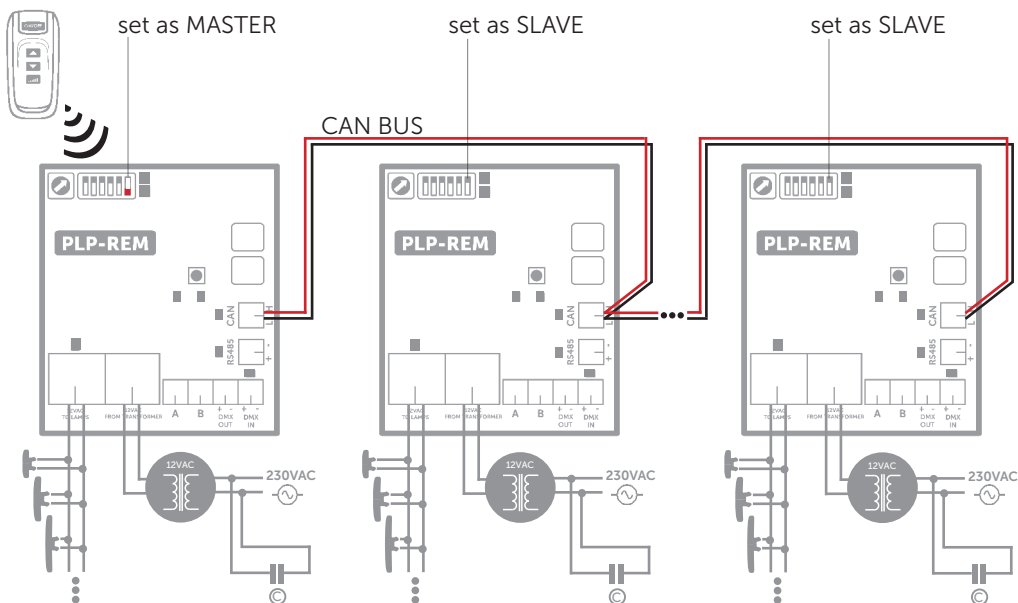







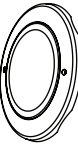

 In a Master/Slave setup, only the PLP-REM that is set as MASTER will react to transmitter commands. Any additional transmitters will need to be paired with this MASTER PLP-REM



\* We recommend using a shielded twisted pair cable (min. 0,5mm<sup>2</sup> - up to 200m) to connect multiple PLP-REM's using the CAN bus.

# Operation Modes

The PLP-REM controller has 2 main operation modes: "ON/OFF control mode" & "PLC control mode". Each mode has it's own functionalities:

	ON/OFF	PLC
Compatible lamps	 <b>VISION Adagio Pro</b>  <b>VISION Spectra</b>  <b>VISION Moonlight</b>	 <b>VISION Adagio Pro</b>  <b>VISION Pro</b>
Switch lamps ON/OFF	YES	YES
Change lamp color	YES <sup>(1)</sup>	YES <sup>(1)</sup>
Operate Relay A & B	YES	YES
Dimming lamps	NO	YES <sup>(1)</sup>
DMX control	NO	YES
RS-485 control	YES <sup>(2)</sup>	YES
Dip switch setting	DIP 1 ON	DIP 1 OFF
Remote keypad type <sup>(3)</sup>	   	   

1) Only for RGB lamps

2) In ON/OFF control mode, only a few RS-485 commands are available (see p 15)

3) Depending on which control mode is selected, the keypad of the transmitter needs to be changed



## DIP switch functionalities

The DIP switch on the main circuit board of the PLP-REM allows the user to customise the way the PLP-REM operates.



**CAUTION:** Always switch off the main power supply to the PLP-REM before changing the DIP switches

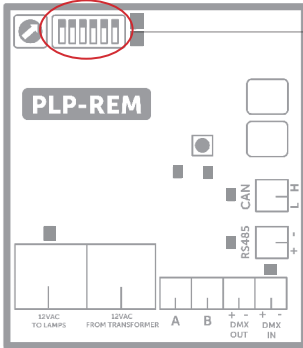

ON position

OFF position

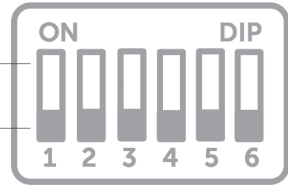

		DIP SWITCH					
function	setting	1	2	3	4	5	6
Operation Mode	ON/OFF	ON					
	PLC	OFF					
Relay A	PULSE mode		ON				
	TOGGLE mode		OFF				
Relay B	PULSE mode			ON			
	TOGGLE mode			OFF			
Fast DMX setting *	FAST				ON		
	STANDARD				OFF		
DMX	NO LOOP					ON	
	LOOP					OFF	
MASTER/SLAVE mode	SLAVE						ON
	MASTER						OFF

\* Fast DMX setting  
Only for Adagio Pro lamps from 2018 and onwards

# Transmitter functions

## OPERATION MODE: PLC (default mode)

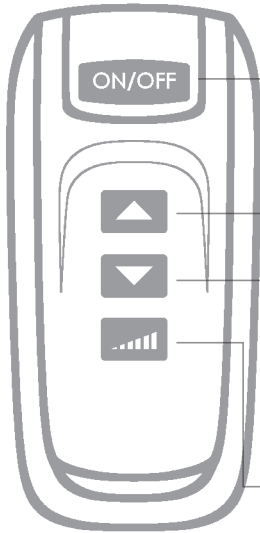

- Short push (< 1 sec):**  
Toggle all lamps ON or OFF <sup>(1)</sup>
- Long push (> 2 sec<sup>(2)</sup>):**  
All lamps & "12VAC TO LAMPS" relay are turned OFF <sup>(1)</sup>
- Short push:**  
Go to next color program
- Long push:**  
Toggle output A ON/OFF
- Short push:**  
Go to the previous color program
- Long push:**  
Toggle output B ON/OFF
- Short push:**  
Select next dimming level:  
100% -- 50% -- 25% ---> 100% -- ...
- Long push:**  
Set lamps to Program 1 (blue) & full brightness

## OPERATION MODE: ON/OFF

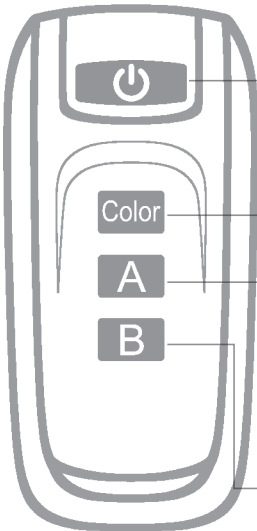

- Short push (< 1 sec):**  
Toggle all lamps ON or OFF
- Short push:**  
Go to next color program
- Long push:**  
Auto sync procedure <sup>(3)</sup>
- Short push:**  
Toggle output A ON/OFF
- Long push:**  
/
- Short push:**  
Toggle output B ON/OFF
- Long push:**  
/

(1) Lamp ON or OFF status is memorized after power down  
 (2) The green LED in the transmitter will light up as soon as you start pressing a button, and will stop after 2 seconds, so you know exactly when to release the button.  
 (3) The lamps will be turned off for 30 seconds and then switched ON/OFF 3 times. This will set all lamps to program 1: blue

## Replacing transmitter Keypad

Depending on which control mode is selected, the keypad of the transmitter needs to be changed:

- Remove the philips head screw and open the transmitter
- Replace the Keypad in the top part of the transmitter housing
- Reassemble in reverse order

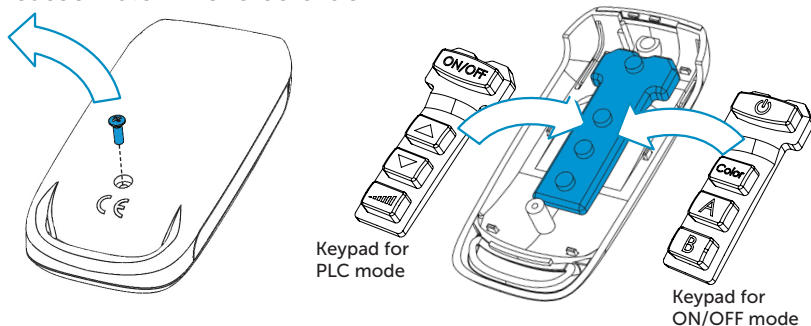

## Pairing the handheld transmitter to the PLP-REM

All handheld transmitters are already paired in the factory and ready to use. In case a problem arises, the pairing process can be done as below:

- 1) Press the pairing button on the circuit board, inside the PLP-REM  
 ---> The BLUE LED will start to blink
- 2) Within 25 seconds, push any button on the handheld transmitter.  
 ---> If the remote is paired correctly, the BLUE LED will flash slowly for 5 times  
 ---> **UNPAIRING:**  
 See RESET procedure: page 16

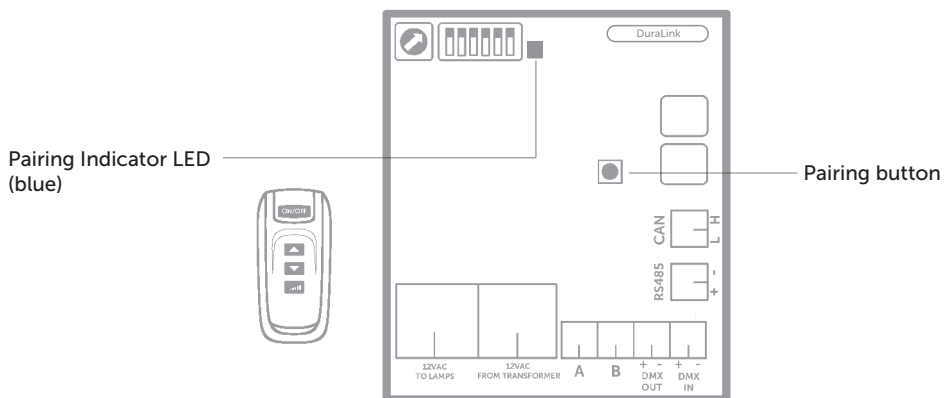

# DMX 512 communication

## Single PLP-REM unit

- 1) Make sure DIP switch 1 is switched OFF.
- 2) Make sure the lights are turned ON with the remote

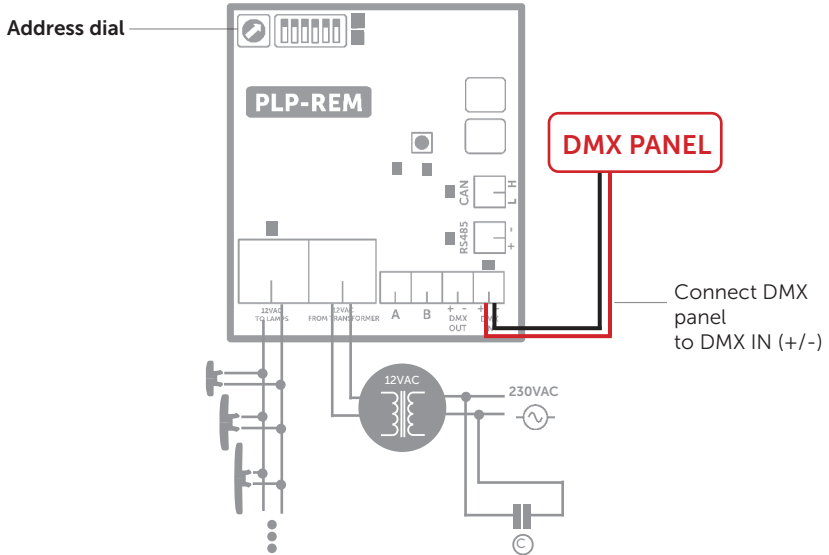

## Address dial setup

Setting the DMX address of the PLP-REM:

Select the desired number on the address dial. The chosen number determines the DMX addresses of the PLP-REM & lamps.

Each lamp uses 3 bytes of DMX data (R-G-B), and all lamps receive the same DMX data from the PLP-REM.

Address dial position	0			1			2			...
	R	G	B	R	G	B	R	G	B	...
DMX address	1	2	3	4	5	6	7	8	9	...

The DMX start address can be overruled by using the RS-485 command: "set DMX start address" (see page 15)

! Remark:

When in DMX512 operation, the handheld transmitter can still select one of three dimming levels and can still switch the lamps. This can not be overridden by DMX512 data.

## Multiple PLP-REM installation

- 1) Connect the DMX panel to the "DMX IN" port of the first PLP-REM
- 2) Connect the PLP-REM's with each other (open loop):  
DMX OUT --> DMX IN (polarized terminals + -)
- 3) Set the DMX address for each PLP-REM via the address dial.
  - Option 1: All PLP-REM's can be set to the same address:  
This implies that all lamps will receive the same DMX data,  
And will all operate identically
  - Option 2: PLP-REM's can be set to different addresses:  
Each PLP-REM will have it's own group of connected lamps  
that will operate identically.  
However, since each PLP-REM has it's own unique address,  
the different lamp groups can be controlled separately

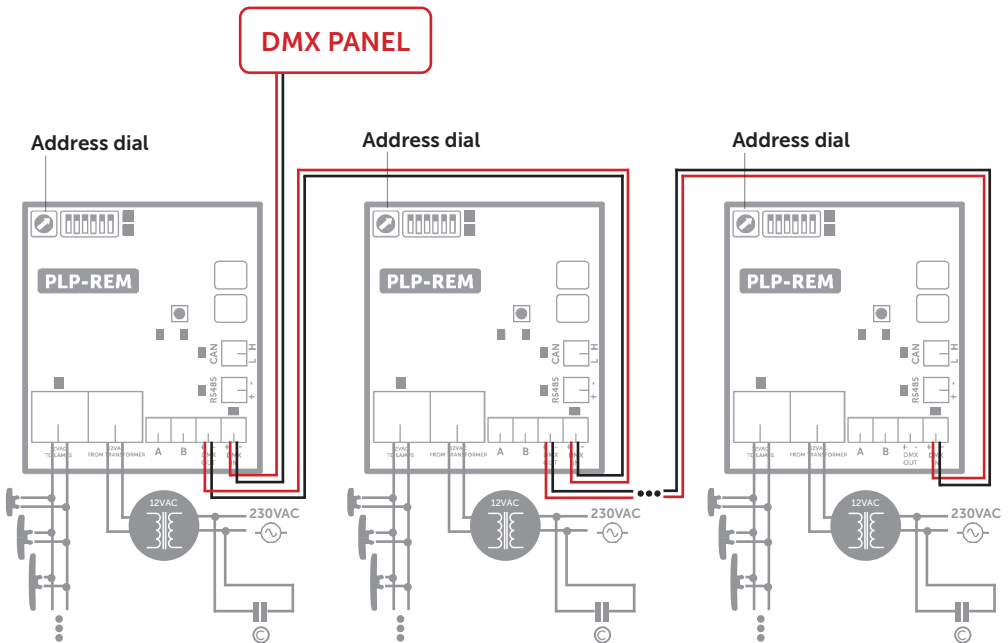

# RS-485 communication

## Single PLP-REM unit

- 1) Make sure DIP switch 1 is switched OFF.
- 2) Make sure the lights are turned ON with the remote first.
- 3) Connect the RS-485 source to the "485" port on the PLP-REM
- 4) Communication settings: 9600, 8, 1, n
- 5) Command list: see page 15

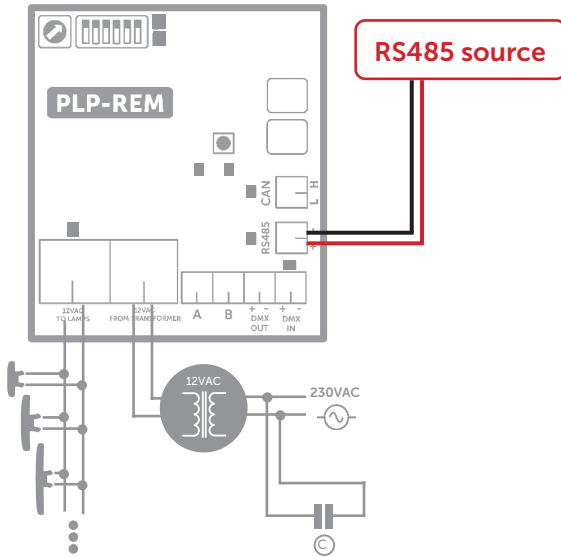

## Multiple PLP-REM installation

- 1) Connect the PLP-REM's with each other via the CAN bus (see page 7)
- 2) Make sure DIP switch 1 is switched OFF
- 3) Make sure the lights are turned ON with the remote first.
- 4) Connect the first PLP-REM with the RS-485 source like described above.  
This PLP-REM will be the Master.
- 5) Communication settings & command list: see above

# RS-485 Command set

Command	Command	Remark	Example	available in ON/OFF mode	available in PLC mode
Lamps OFF	PL0	All lamps OFF		X	X
Lamps ON	PL1	All lamps ON		X	X
Program UP	PsU	Jump to next program		X	X
Program Down	PsD	Return to previous program			X
Set Program	PSxx	xx is the decimal representation of the program number (01 - 14)	PS06 = jump to program 6		X
Auto sync procedure	PsS	executes the auto sync procedure (see page 10)		X	X
White 1	PW1	Jump to White 1 (program 12)			X
White 2	PW2	Jump to White 2 (program 13)			X
White 3	PW3	Jump to White 3 (program 14)			X
Set RGB	PCrrrgggbbbb	rrr, ggg and bbb are the decimal representation of the RGB value (with leading zero's)	1) PC255128064 = Full output level on Red color, half output level on Green color, 1/4 output level on Blue color 2) PC255255255 = All colors at full output level 3) PC000000000 = All colors OFF		X
Set Dim value	PDxxx	set the OUTPUT value of the lamp in % (000 - 100)	PD075 = 75% output level (on all LED's)		X
set DMX startAddress	PAxxxxyz	y = 'e' or 'E'	PA035E = set DMX start address to 35 [35(R), 36(G), 37(B)]		X
Set color in percentage	Pprngbe	variable size, rgb = ASCII 0-255, e = end character	Pp25050100e = Red 25%, Green 50%, Blue 100%		X
Set color in hex	Pcrgbe	variable size, rgb = ASCII 0-255, e = end character	Pc64128255e = Red 25%, Green 50%, Blue 100%		X
Relay A control	PRAX	x = 1 (ON), 0 (OFF), P (Pulse)   this overrides dipswitch	PRA1 = Relay A ON PRA0 = Relay A OFF	X	X
Relay B control	PRBx	x = 1 (ON), 0 (OFF), P (Pulse)   this overrides dipswitch	PRB1 = Relay B ON PRB0 = Relay B OFF	X	X
ON/OFF relay control	PRMx	x = 1 (ON), 0 (OFF)	PRM1 = Relay ON/OFF control ON	X	X
Color temperature	PTxyz	x = ten thousand ; y = thousand ; z = hundred	PT035 = Set white color temperature to 3500K (in steps of 500K)		X

# RESET procedure

## RESET procedure for the control board

- 1) Make sure the PLP-REM is powered ON
- 2) Press and hold the RESET button on the logic board
- 3) The blue LED will light up
- 4) Release the RESET button when the blue LED turns off

 *The control board has been RESET.  
And all transmitters have been unpaired.*

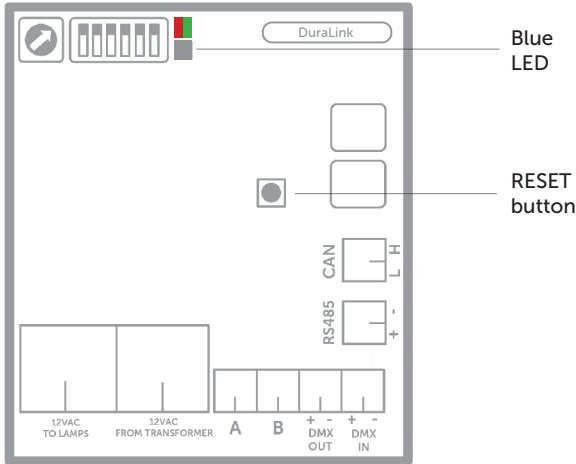

## Transmitter battery

### Replacing transmitter battery:

- Remove the philips head screw and open the transmitter
- Replace the battery, respecting the polarity

*Battery type: A23 12V*

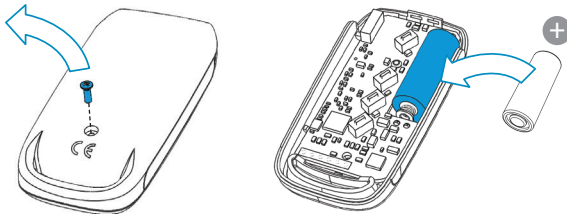



## Troubleshooting

### PROBLEM

The PLP-REM doesn't react to transmitter commands

### SOLUTION

- Perform a RESET procedure
- Check the battery of the handheld transmitter (see p.16)
- The transmitter is not paired-correctly with the PLP-REM. Repeat the pairing process
- Reduce the distance between handheld transmitter and PLP-REM and/or remove obstacles
- Check the General status light on the logic board. If it's red, then the secondary voltage is too high (>14VAC) or there is a short circuit
- Check the LED on the small DURA-LINK circuit board (top right corner). This LED needs to blink each time a transmitter button is pressed. If the LED works, there might be a problem with the logic board

---

The pool lights don't work or don't change colors correctly

- Perform a RESET procedure
- Check if all connections are made according to the electrical scheme.
- Switch the PLP-REM to ON/OFF mode (DIP switch nr 1) and check if the lamps work

---

Handheld transmitter does not function anymore after firmware update of the PLP-REM for Link-Touch compatibility

- Buy a new TX868 transmitter that has updated firmware

## Pool light wiring instructions



# WARNING



- (GB) Cable installation guidelines**
- (NL) Richtlijnen voor bekabeling**
- (DE) Anleitung zur Verkabelung**
- (FR) Instructions de câblage**
- (IT) Istruzioni di collegamento**
- (ES) Instrucciones para ajuste del cableado**

*Please refer to the manual of your DURAVISION® pool light*



Manual downloads:  
[www.duratech.be/downloads](http://www.duratech.be/downloads)

Not following the instructions for cable cross section and transformer VA ratings may result in lamp malfunctioning and may result in having to rewire the installation. The manufacturer's warranty does not apply in this situation.

Please refer to the manual of your DURAVISION pool light for detailed information about cable cross section and maximum length.

## Wiring remarks

1. Third party equipment such as frequency inverters and electric motors can generate excessive noise on the 230VAC / 400VAC power line. This noise might be injected into the adjacent 12VAC power line and disturb the power line communication towards the DURAVISION lights.

 Keep 230VAC / 400VAC power line cables at least 50cm separated over their full length from the 12VAC power line towards any RGB lights

 Do not mix 12VAC and 230VAC / 400VAC power line cables into the same cable trays

2. Floating cores in a multi-core cable are not allowed because it disturbs PLC communication.

 We recommend using 2 CORE cables for all Adagio Pro lights to avoid PLC communication issues

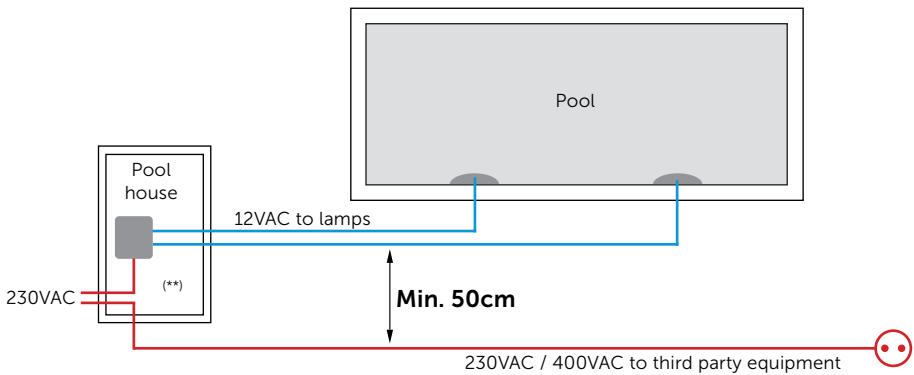

(\*\*) Do not mix 12VAC and 230VAC / 400VAC power line cables into the same cable trays





