

# NIGER-KNG

SPECIAL FOR RE-CIRCULATION  
TILL 26 m<sup>3</sup>/H



- ➔ Water features, hydro massage, spas and general re-circulation
- ➔ Impeller in Noryl and mechanical seal in AISI 316®
- ➔ Enclosed motor, protection class IP55, class F
- ➔ Silent operation
- ➔ Usage: water features, hydro massage, spas and general re-circulation

	SKU	Ref.	Type HP	P2 (W) <sup>1</sup>	P1 (W) <sup>2</sup>	Amps (A) <sup>3</sup>	A (mm)	Flow rate (m <sup>3</sup> /h)*	Weight (kg)	Vol. (m <sup>3</sup> )	qty/pallet	
SINGLE PHASE	36-232050	KNG 075DM	0.75	552	750	3,8	3,8	12	11.5	0.028	30	
	36-232075	KNG 100DM	1.00	736	1000	5	5	15.98	12	0.028	30	
	36-232113	KNG 150DM	1.50	1104	1600	7,5	7,5	22.4	14.5	0.028	24	
	36-232150	KNG 200DM	2.00	1472	1920	9	9	26.2	15.5	0.028	24	
THREE PHASE	36-234050	KNG 075DT1	0.75	552	750	3,4/2	412	12	11.5	0.028	30	IE2 ✓
	36-234075	KNG 100DT1 IE3	1.00	736	1000	3,5/2,1	412	15.9	12	0.028	30	IE3 ✓
	36-234113	KNG 150DT1 IE3	1.50	1104	1600	3,6/2,2	442	22.4	14.5	0.028	24	IE3 ✓
	36-234220	KNG 200DT1 IE3	2.00	1472	1920	5/2,9	442	26.2	15	0.028	24	IE3 ✓

<sup>1</sup> Nominal power of the motor P2 (W)    <sup>2</sup> P1 Max (W) (Maximum consumption of the pump)    <sup>3</sup> Amps at P1 Max (A)    \* 10 m water column pressure    M.O.Q. :1

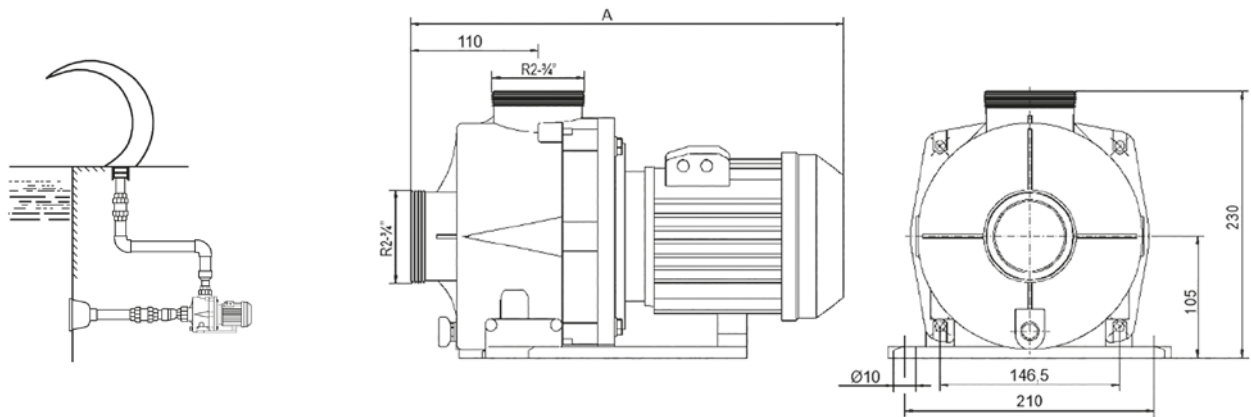

## Technical Specifications

Max. water temp. / Max. pressure	50°C / 2,5 bar
Connection (DIN slip included, for others please ask)	Ø 50 mm <= 1 HP Ø 63 mm > 1 HP All bodies have a 2" thread. Possibility of having ANSI connection 1.5" by buying code MAINS15 or 2" with the code MAINS20.
Mechanical seal	AISI 316, suitable for salt water
Motor-drive specifications	Class F, IP55, 50 Hz, 2.850 rpm
Housing/impeller	PP + F.G./Noryl®

